



ONIAR



As of January 2022 all Oniar trailers are available with EU whole vehicle type approval allowing Oniar trailers to be registered for use on public roads. The type approval is recognized by all EU member states and most of its neighboring countries which accept this regulation.

The EU regulation 167/2013 establishes a set of rules on safety and environmental protection for forestry and other agricultural vehicles. The regulation provides harmonized technical standards for the construction of towable vehicles and general requirements for obtaining type approval.

The maximum allowed driving speed on public roads is 30 km/h. To fulfill type approval requirements, the trailer must be equipped with either 2 wheel or 4 wheel hydraulic or pneumatic brake system, rear- and sidelights, reflectors and specific size wheels. Double-line hydraulic system and double-line pneumatic system Oniar trailers are suitable for most common tractor models sold in Europe.

Trailers are divided into 4 different groups based on the cross-section of the loading area and frame profile. Type approval is available to all possible brake combinations with and without a driving system. From trailer technical information it is possible to find each group-specific gross weight table. It presents the maximum allowed gross weight on public roads depending on the number of brakes, position of driving motors (front and/or rear axle) and the size of wheels intended for the trailer.

ONIAR



TRAILER 34 - GROUP 0

Technical information		34
Frame type		Single beam
Cross section of loading area	m ²	2,1
Frame profile	mm	200x200x8
Wheel hubs		80x80 - 6
Wheels		400/60-15,5
Suitable cranes		6800

Group 0 gross weight	
34	
2 brakes / 4 brakes	
10 000 kg / 13 000 kg	



TRAILER 34 | 400/60-15,5 | Ø 870

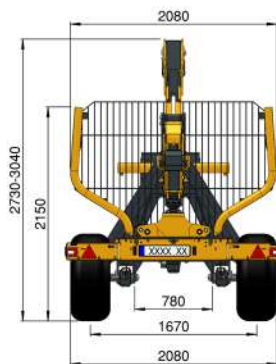
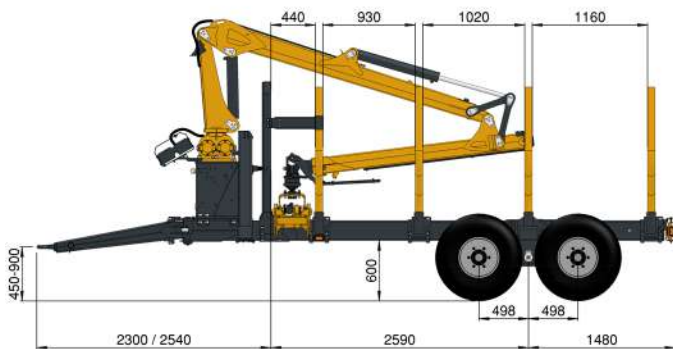



Technical information		134	137	142
Frame type		Double beam	Double beam	Double beam
Cross section of loading area	m ²	2,3	2,3	2,3
Frame profile	mm	2x(200x100x8)	2x(200x100x8)	2x(200x100x8)
Wheel hubs		80x80 - 6	80x80 - 6	90x90 - 8
Wheels		400/60-15,5	500/50-17	550/45-22,5
Suitable cranes		6800 / 8000	6800 / 8000 7500	6800 / 8000 7500 / 8750 / 8800

Group 1 gross weight		
134	137	142
2 brakes / 4 brakes		
10 000 kg / 13 500 kg	10 000 kg / 14 500 kg	12 500 kg / 15 500 kg
2 WD front axle : 2 brakes / 4 brakes		
---- / ----	6600 kg (pneumatic) / 9000 kg (pneumatic) 8000 kg (hydraulic) / 12 000 kg (hydraulic)	10 500 kg / 15 500 kg
2 WD rear axle : 2 brakes / 4 brakes		
---- / ----	10 000 kg / 12 000 kg	12 500 kg / 15 500 kg
4 WD : 2 brakes / 4 brakes		
---- / ----	6600 kg (pneumatic) / 9000 kg (pneumatic) 8000 kg (hydraulic) / 12 000 kg (hydraulic)	10 500 kg / 15 500 kg



TRAILER 134 | 400/60-15,5 | Ø 875

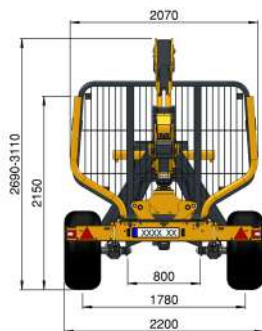
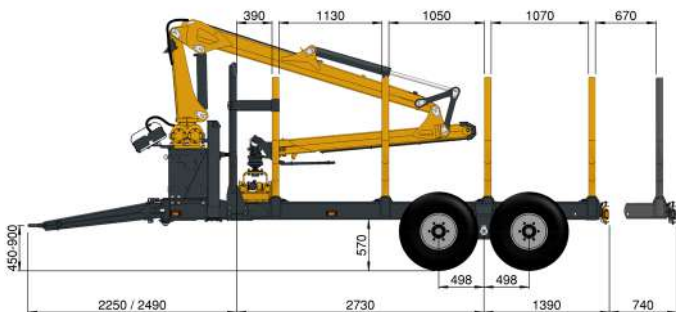

TRAILER 137 | 500/50-17 | Ø 945

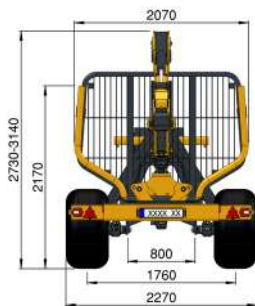
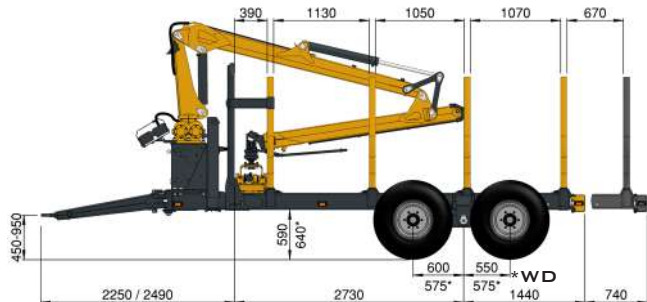

TRAILER 142 | 550/45-22,5 | Ø 1070

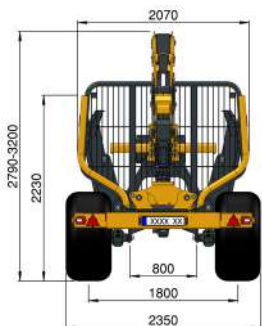
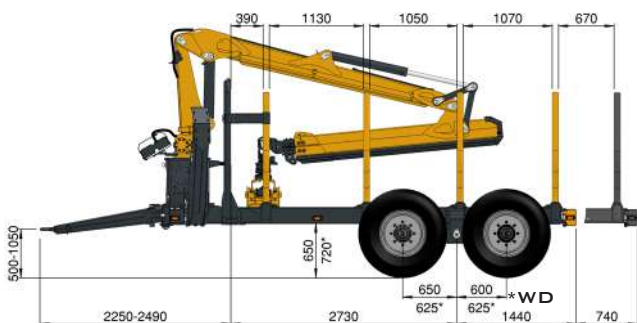

TRAILERS 134 / 137 / 142 FRAME WITH EXTRA POLES

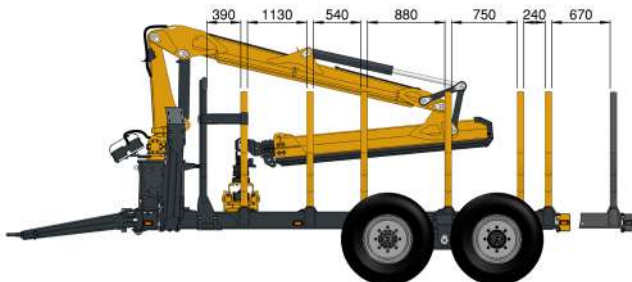

ONIA

TRAILERS 134 / 137 / 142 - GROUP 1



Technical information		237	242 / 242 R	246 / 246 R	246 e / 246 Re
Frame type		Double beam	Double beam extended (R)	Double beam extended (R)	Double beam extended (R)
Cross section of loading area - standard poles	m ²	2,6	2,6	2,6	2,6
Cross section of loading area - FW poles	m ²	---	2,4 - 5	2,4 - 5	2,4 - 5
Frame profile	mm	2x(200x120x8)	2x(200x120x8)	2x(200x120x8)	2x(200x120x8)
Wheel hubs	mm	80x80 - 6	90x90 - 8	100x100 - 8	100x100 - 8
Wheels		500/50-17	550/45-22,5	600/50-22,5	710/40-22,5 (e)
Suitable cranes		6800 / 8000 7500	6800 / 8000 7500 / 8750 / 8800	6800 / 8000 7500 / 8750 / 8800	6800 / 8000 7500 / 8750 / 8800

Group 2 gross weight			
237	242 / 242 R	246 / 246 R	246 e / 246 Re
2 brakes / 4 brakes			
10 000 kg / 15 000 kg	12 500 kg / 17 000 kg	12 500 kg / 18 000 kg	12 500 kg / 15 000 kg
2 WD front axle : 2 brakes / 4 brakes			
6600 kg (pneu) / 9000 kg (pneu) 8000 kg (hydr) / 12 000 kg (hydr)	10 500 kg / 16 000 kg	10 500 kg / 17 000 kg	10 500 kg / 15 000 kg
2 WD rear axle : 2 brakes / 4 brakes			
10 000 kg / 12 000 kg	12 500 kg / 16 000 kg	12 500 kg / 17 000 kg	12 500 kg / 15 000 kg
4 WD : 2 brakes / 4 brakes			
6600 kg (pneu) / 9000 kg (pneu) 8000 kg (hydr) / 12 000 kg (hydr)	10 500 kg / 16 000 kg	10 500 kg / 17 000 kg	10 500 kg / 15 000 kg



TRAILER 237 | 500/50-17 | Ø 945

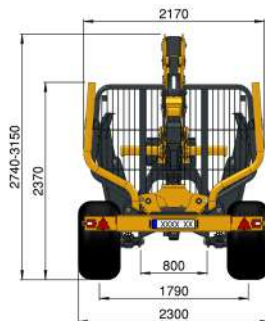
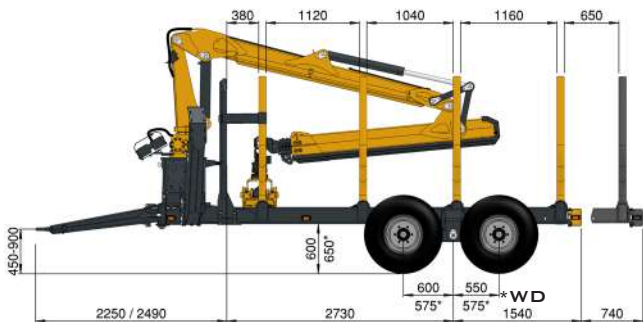

TRAILER 242 | 550/45-22,5 | Ø 1070

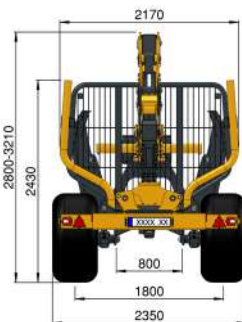
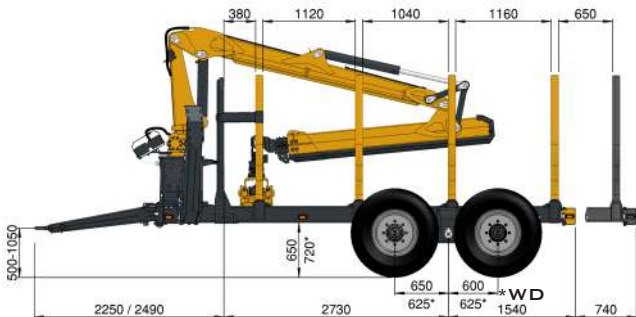

TRAILER 242R | 550/45-22,5 | Ø 1070

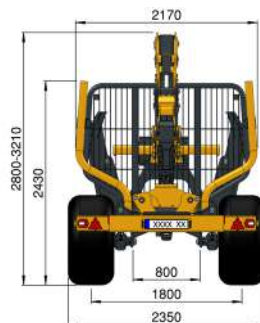
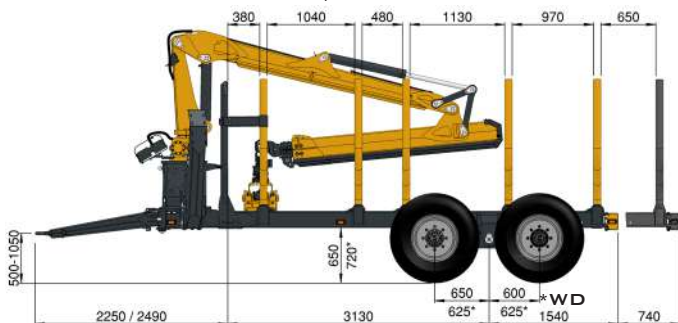

TRAILER 242R | FW | 550/45-22,5 | Ø 1070

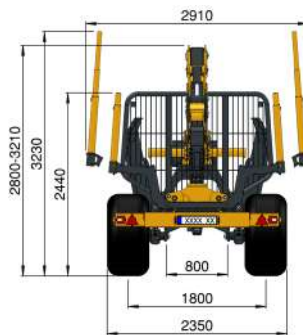
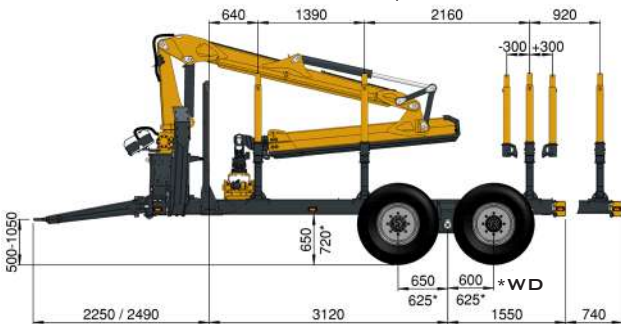

TRAILERS 237 / 242 / 246 - GROUP 2

TRAILER 246 | 600/50-22,5 | Ø 1170

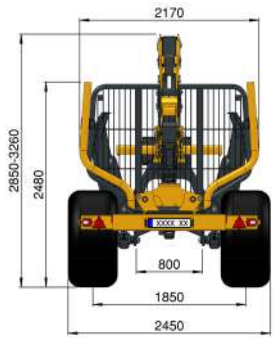
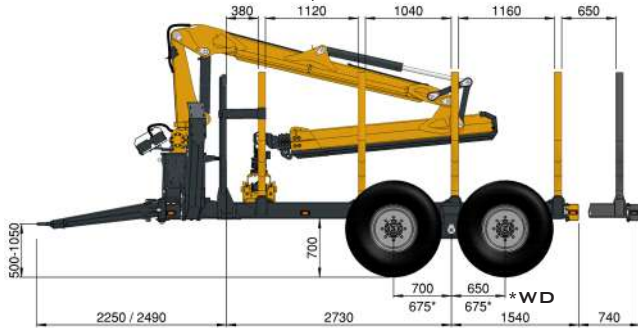

TRAILER 246R | 600/50-22,5 | Ø 1170

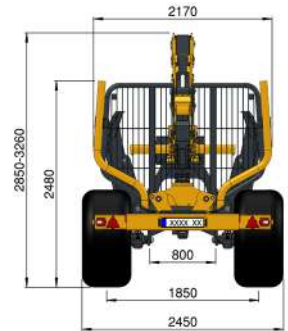
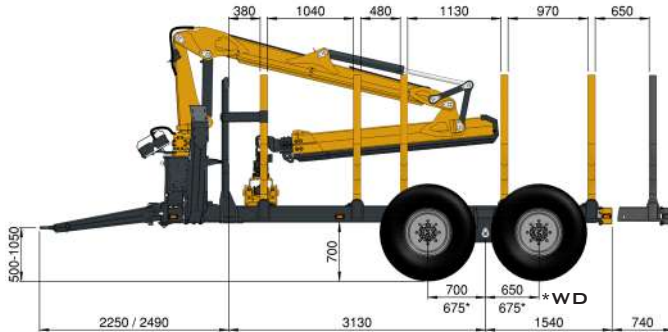

TRAILER 246R | FW | 600/50-22,5 | Ø 1170

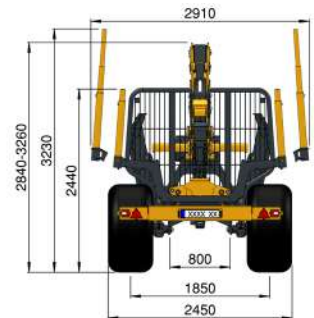
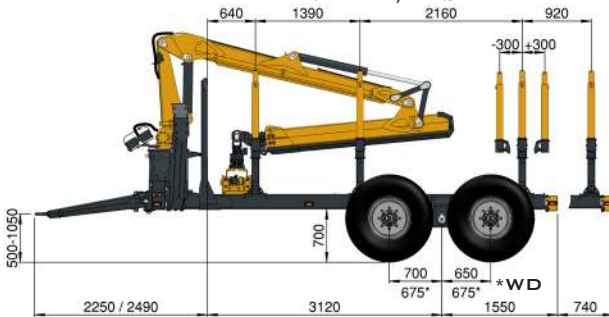

TRAILER 246E | 710/40-22,5 | Ø 1170

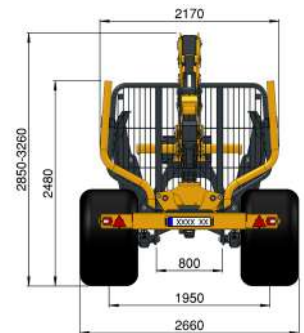
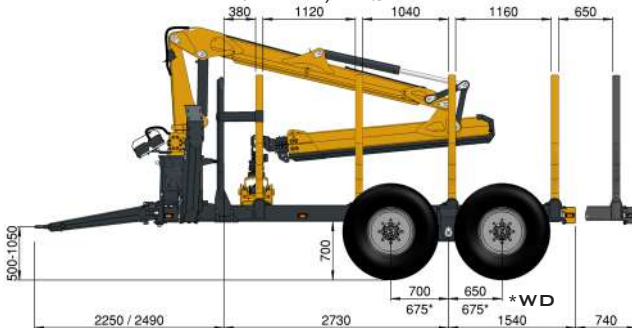

TRAILER 246RE | 710/40-22,5 | Ø 1170

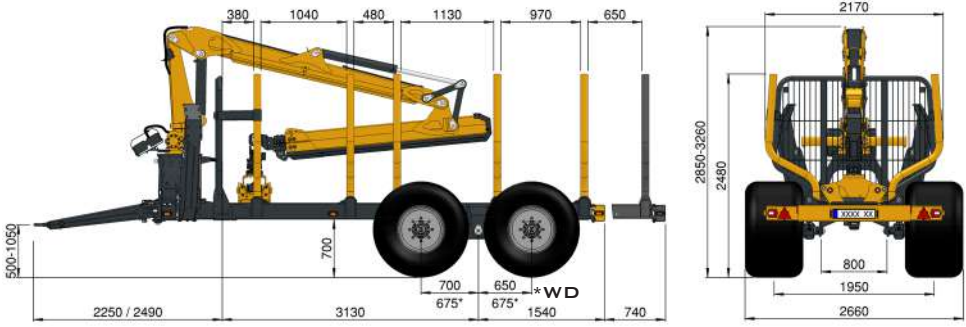

TRAILER 246RE | FW | 710/40-22,5 | Ø 1170

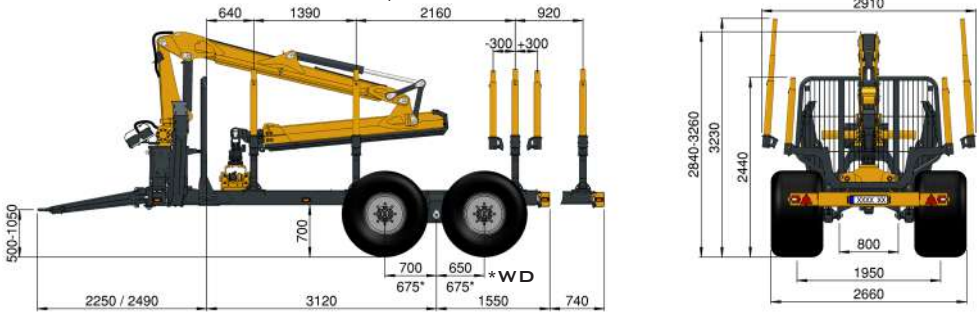

TRAILER 237 / 242 / 246 FRAME WITH EXTRA POLES

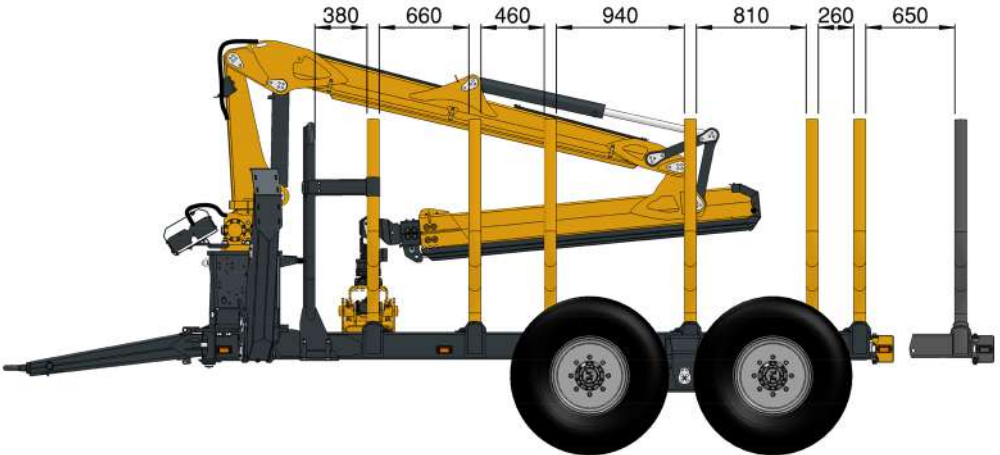



Technical information		342 / 342 R	346 / 346 R	346 e / 346 Re
Frame type		Double beam extended (R)	Double beam extended (R)	Double beam extended (R)
Cross section of loading area - standard poles	m ²	3	3	3
Cross section of loading area - FW poles	m ²	2,8 - 5,6	2,8 - 5,6	2,8 - 5,6
Frame profile	mm	2x(250x150x8)	2x(250x150x8)	2x(250x150x8)
Wheel hubs	mm	90x90 - 8	100x100 - 8	100x100 - 8
Wheels		550/45-22,5	600/50-22,5	710/40-22,5 (e)
Suitable cranes		7500 / 8750 / 8800 10200	7500 / 8750 / 8800 10200	7500 / 8750 / 8800 10200

Group 3 gross weight		
342 / 342 R	346 / 346 R	346 e / 346 Re
2 brakes / 4 brakes		
13 000 kg / 19 000 kg	13 000 kg / 20 500 kg	13 000 kg / 16 000 kg
2 WD front axle : 2 brakes / 4 brakes		
11 000 kg / 17 000 kg	11 000 kg / 18 000 kg	11 000 kg / 16 000 kg
2 WD rear axle : 2 brakes / 4 brakes		
13 000 kg / 17 000 kg	13 000 kg / 18 000 kg	13 000 kg / 16 000 kg
4 WD : 2 brakes / 4 brakes		
11 000 kg / 17 000 kg	11 000 kg / 18 000 kg	11 000 kg / 16 000 kg



TRAILER 342 | 550/45-22,5 | Ø 1070

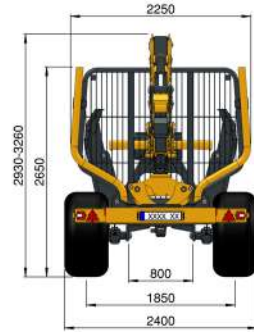
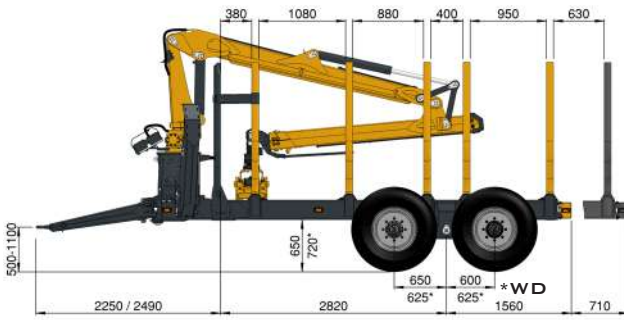

TRAILER 342R | 550/45-22,5 | Ø 1070

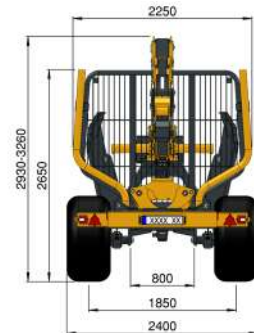
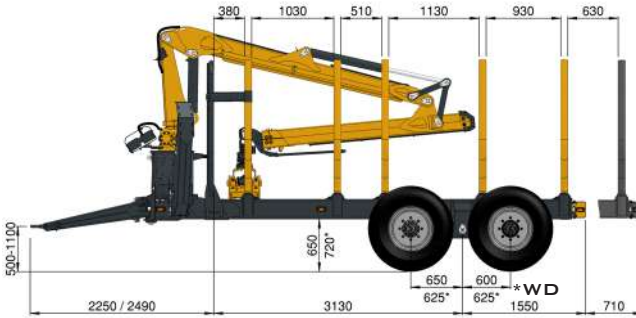

TRAILER 342 | FW | 550/45-22,5 | Ø 1070

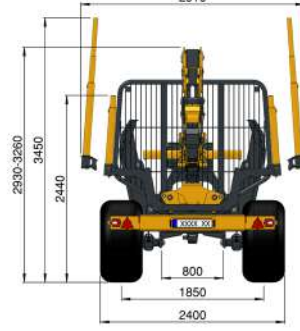
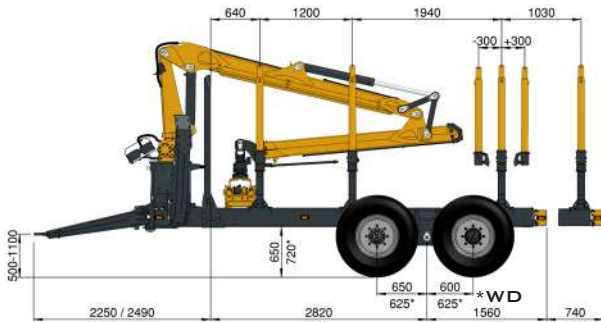

TRAILER 342R | FW | 550/45-22,5 | Ø 1070

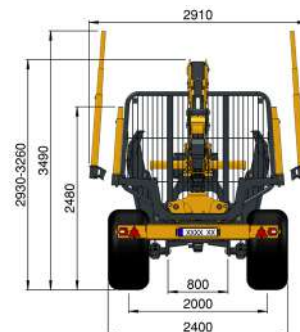
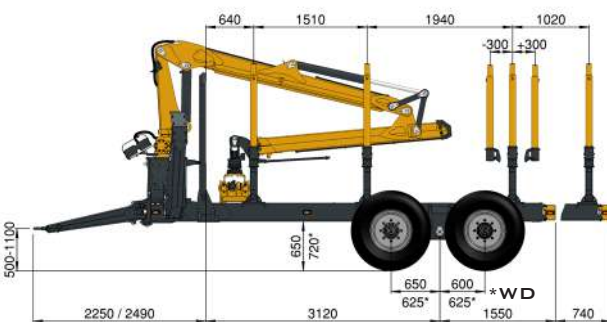

TRAILERS 342 / 346 - GROUP 3

TRAILER 346 | 600/50-22,5 | Ø 1170

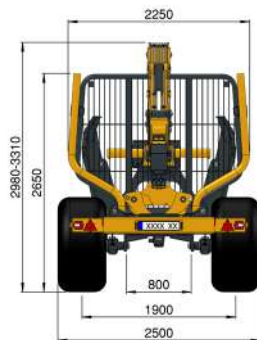
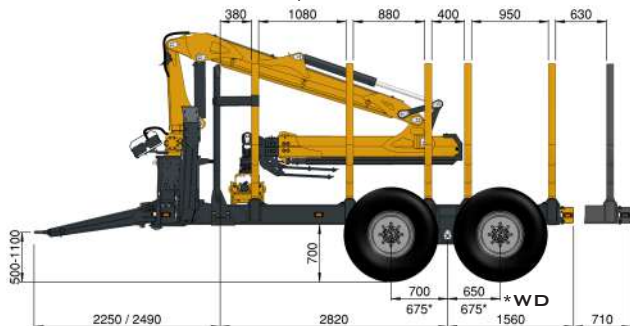

TRAILER 346R | 600/50-22,5 | Ø 1170

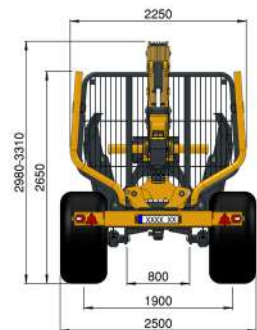
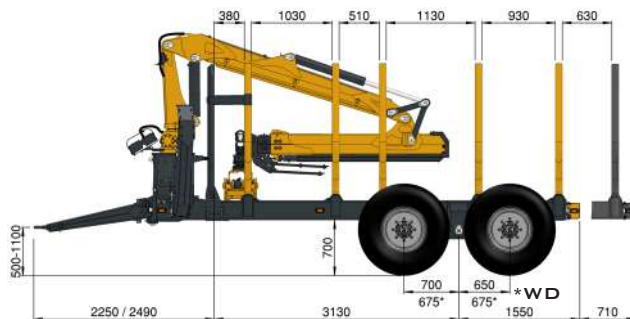

TRAILER 346E | 710/40-22,5 | Ø 1170

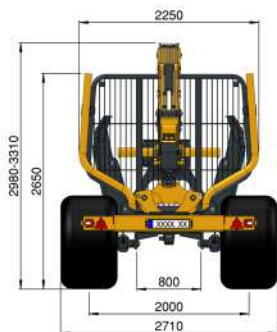
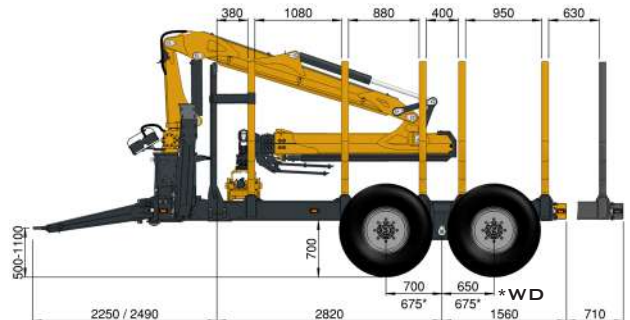

TRAILER 346RE | 710/40-22,5 | Ø 1170

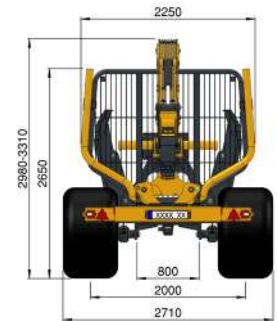
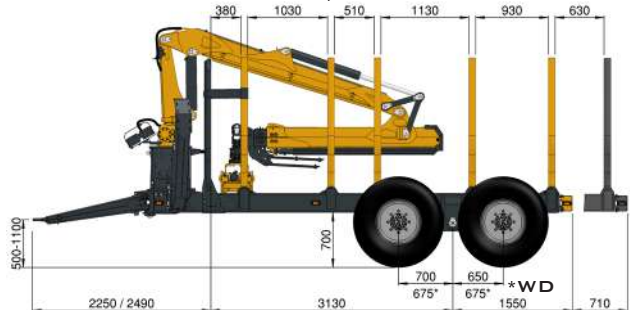

TRAILER 346 | FW | 600/50-22,5 | Ø 1170

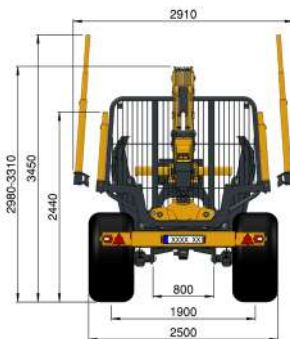
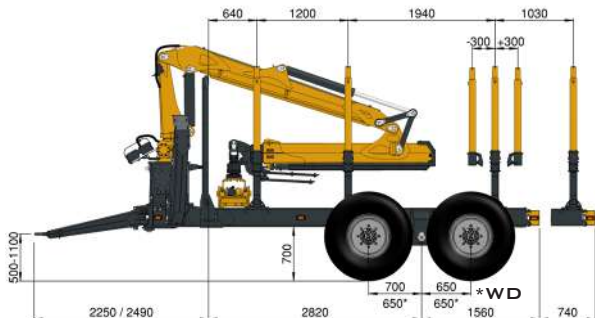

TRAILER 346R | FW | 600/50-22,5 | Ø 1170

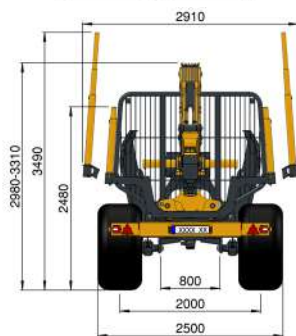
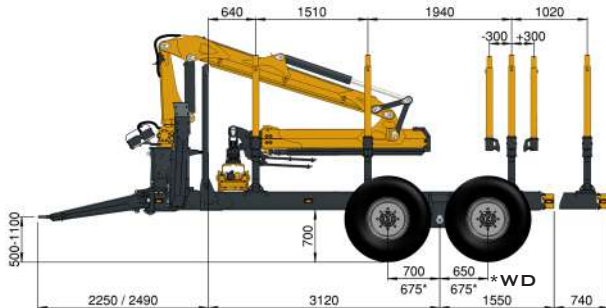

TRAILER 346E | FW | 710/40-22,5 | Ø 1170

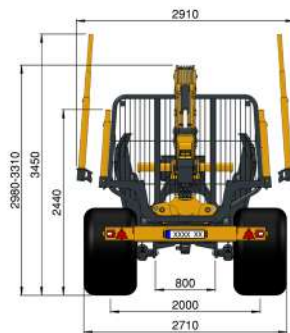
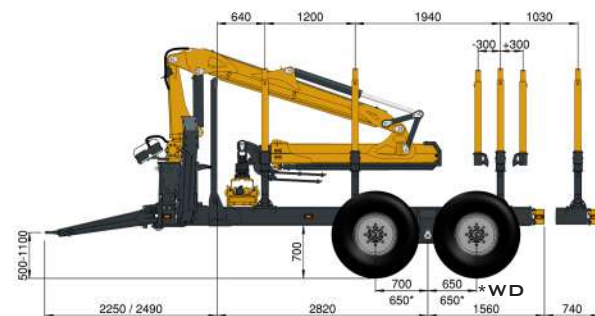

TRAILER 346Re | FW | 710/40-22,5 | Ø 1170

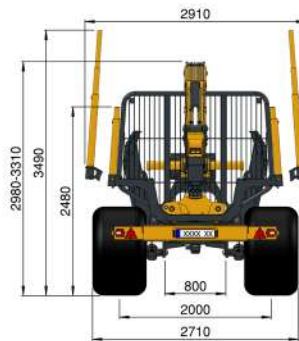
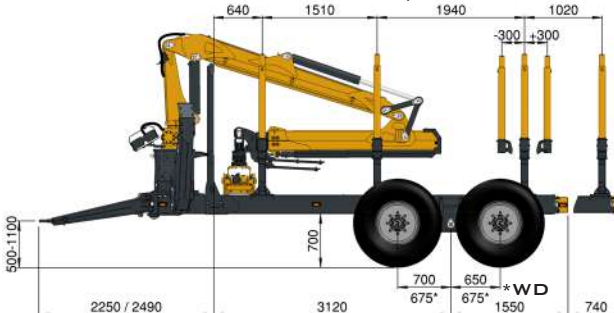

TRAILERS 342 / 346 - GROUP 3

TRAILERS 342 / 346 FRAME WITH EXTRA POLES

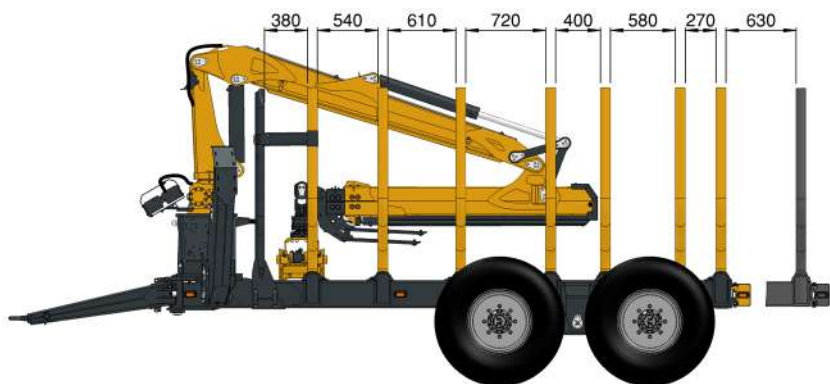

TRAILERS 342R / 346R EXTENDED FRAME WITH EXTRA POLES

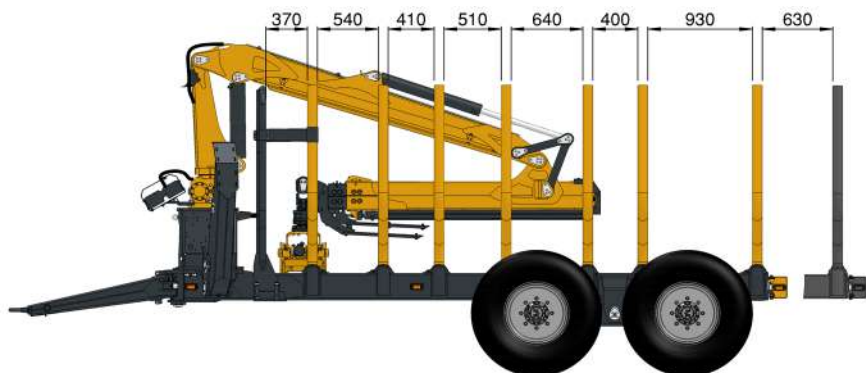



LOAD AREA WITH REGULAR POLES

GROUP 0

2,1 m²

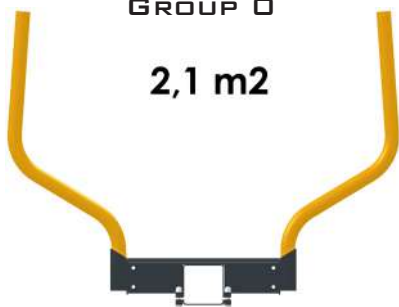

GROUP 1

2,3 m²



GROUP 2

2,6 m²



GROUP 3

3 m²



ONIAR

GROUP 2 POLES WITHOUT
LOAD AREA EXTENSIONS



WITH
POLE EXTENTIONS

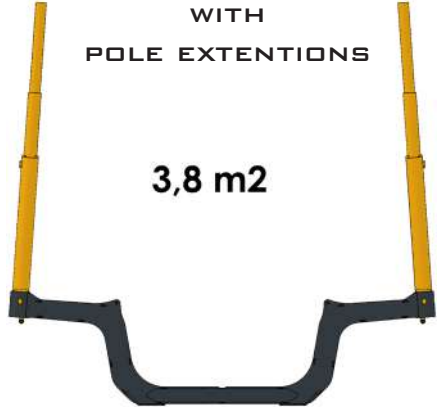

GROUP 2 POLES WITH LOAD
AREA EXTENSIONS



WITH
POLE EXTENTIONS



GROUP 2 POLES WITH LOAD
AREA EXTENSIONS IN THE
OPEN POSITION



WITH
POLE EXTENTIONS

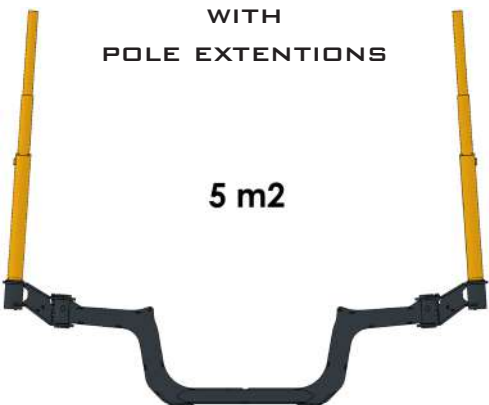

GROUP 3 POLES WITHOUT
LOAD AREA EXTENSIONS



2,8 m²

WITH
POLE EXTENTIONS



4,2 m²

GROUP 3 POLES WITH LOAD
AREA EXTENSIONS



3 m²

WITH
POLE EXTENTIONS



4,4 m²

GROUP 3 POLES WITH LOAD
AREA EXTENSIONS IN THE
OPEN POSITION



3,8 m²

WITH
POLE EXTENTIONS



5,6 m²



CRANES - 6800 / 8000



ONIAR

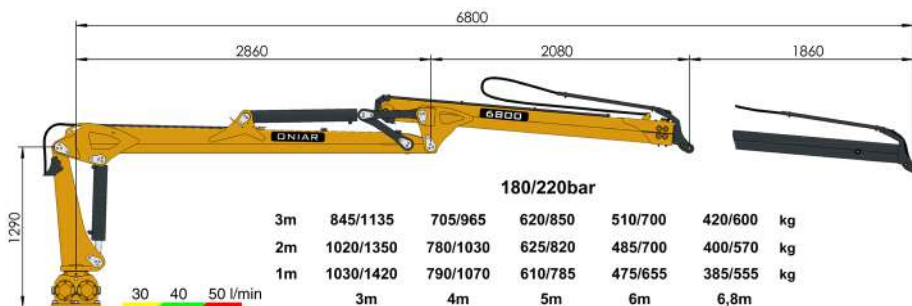

Technical information		6800	8000
Maximum reach	m	6,8	8,0
Work pressure	bar	180 / 220	180 / 220
Lifting force (gross)	kNm	49 / 60	49 / 60
Slewing torque (gross)	kNm	15,5 / 19	15,5 / 19
Optimal oil flow (FIX system)	l/min	30-45	30-45
Flange rotator	kNm	45	45
Suitable trailers		34 134 / 137 / 142 237 / 242	134 / 137 / 142 237 / 242
Suitable grapples		G18E / G20	G18E / G20

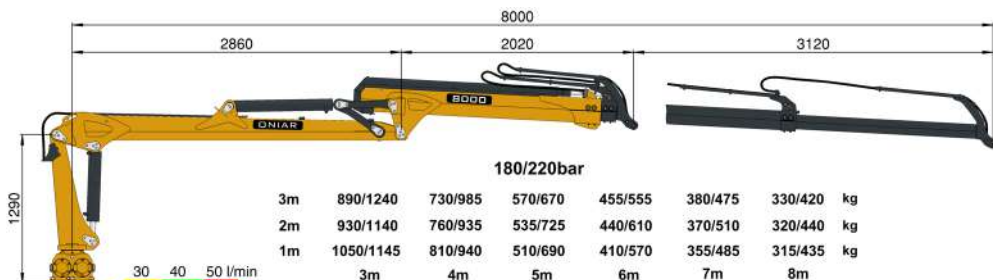

ONIAR

CRANES - 6800 / 8000

CRANES - 7500 / 8750 / 8800



ONIAR

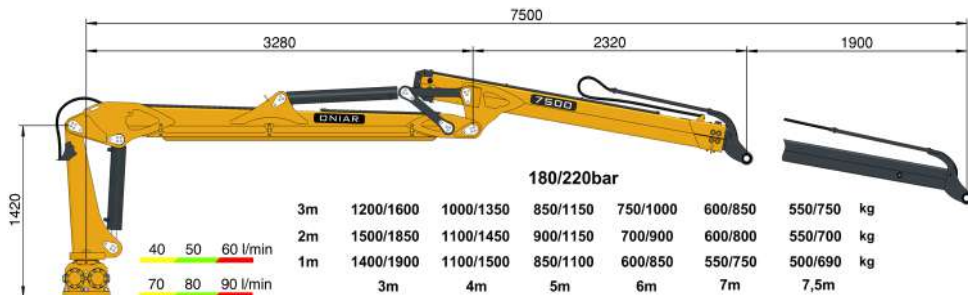

Technical information		7500	8750	8800
Maximum reach	m	7,5	8,75	8,8
Work pressure	bar	180 / 220	180 / 220	180 / 220
Lifting force (gross)	kNm	69 / 85	69 / 85	69 / 85
Slewing torque (gross)	kNm	21 / 26	21 / 26	21 / 26
Optimal oil flow (FIX system)	l/min	45-60	45-60	45-60
Optimal oil flow (LS system)	l/min	80	80	80
Flange rotator	kNm	55	55	55
Suitable trailers		137 / 142 237 / 242 / 246 342 / 346	142 242 / 246 342 / 346	142 242 / 246 342 / 346
Suitable grapples		G18E / G20 G22E / G24	G18E / G20 G22E / G24	G18E / G20 G22E / G24

CRANE - 10200

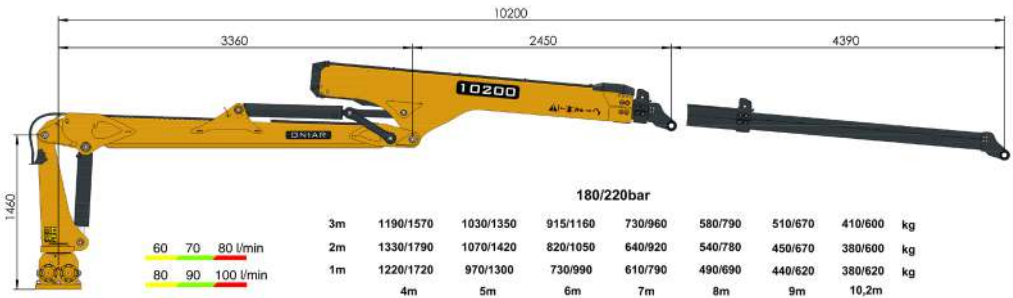

Technical information		10200
Maximum reach	m	10,2
Work pressure	bar	180 / 220
Lifting force (gross)	kNm	89 / 109
Slewing torque (gross)	kNm	23 / 28
Optimal oil flow (FIX system)	l/min	60-70
Optimal oil flow (LS system)	l/min	90
Flange rotator	kNm	55
Suitable trailers		342 / 346
Suitable grapples		G22E / G24 G25E / G27





LOG GRAPPLES

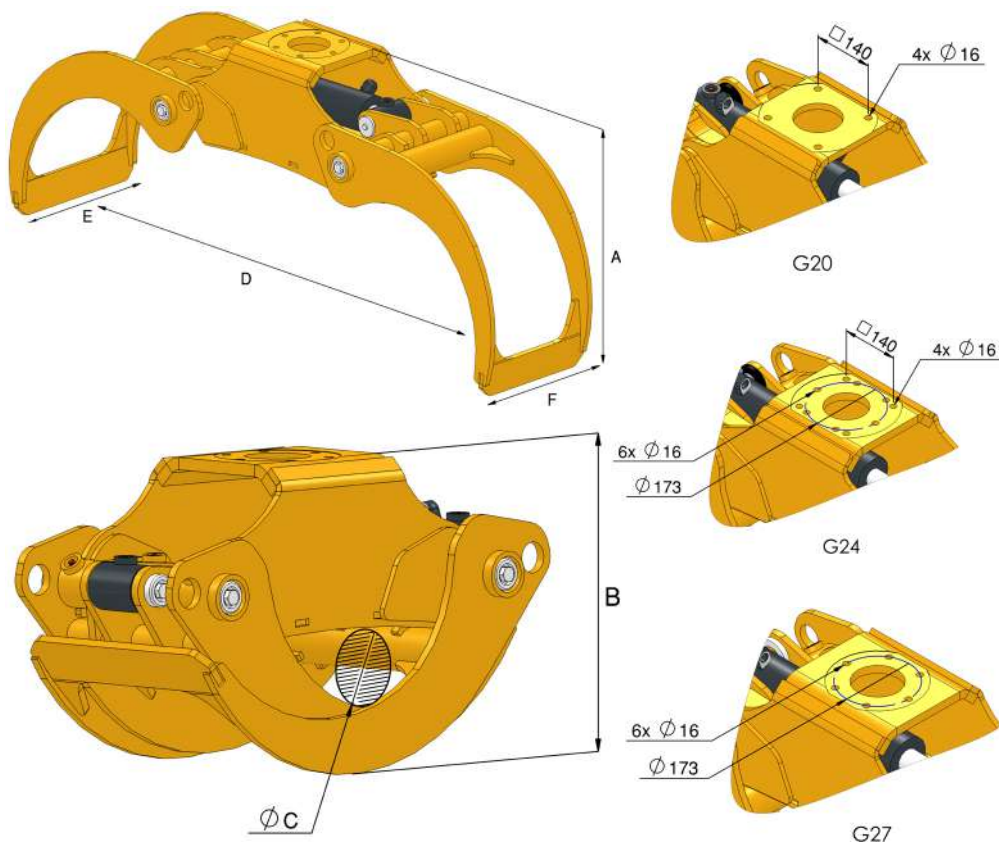

		G20 / G20H	G24 / G24H	G27 / G27H
A	mm	620	665	700
B	mm	435	490	505
C	mm	100	115	125
D	mm	1340	1470	1600
E	mm	362	392	412 / 443
F	mm	318	342	362
Weight	kg	130	180	195 / 215
Volume	m ²	0,20	0,24	0,27
Working pressure	bar	180-220	180-220	180-220
Gripping force	kN	7,6	11	13,4
Optimal oilflow	l/min	30	40	50

ONIAR

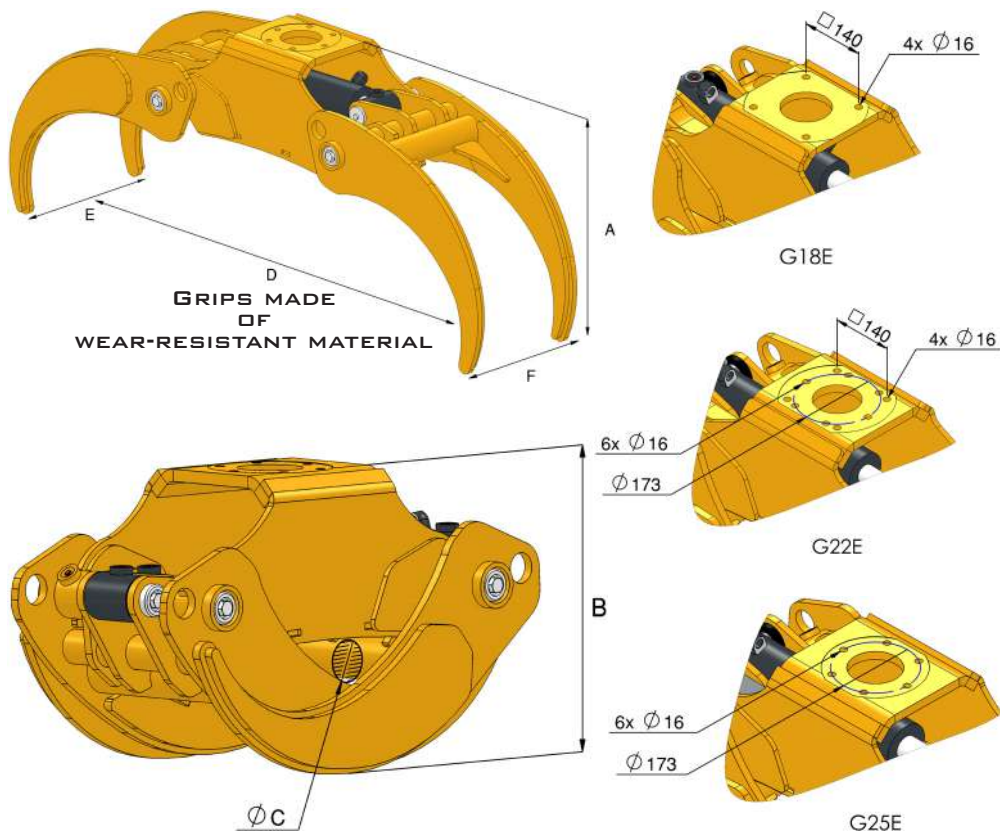

		G18E	G22E	G25E
A	mm	590	685	685
B	mm	435	490	490
C	mm	70	70	70
D	mm	1340	1470	1550
E	mm	390	430	450
F	mm	318	344	364
Weight	kg	140	215	230
Volume	m ³	0,18	0,22	0,25
Working pressure	bar	180-220	180-220	180-220
Gripping force	kN	7,6	11	13,4
Optimal oilflow	l/min	30	40	50







Nokian Forest King F2



Agricultural tire



Reinforced wheels with valve protection



Forestry tire

	Nokian Forest King F2	Agricultural tire (flotation)	Forestry tire (traction)	Reinforced wheel
400/60-15,5	-	X	-	X
500/50-17	-	X	-	X
550/45-22,5	-	X	X	X
600/50-22,5	X	X	X	X
700/40-22,5	-	-	X	X
710/40-22,5	X	-	-	X

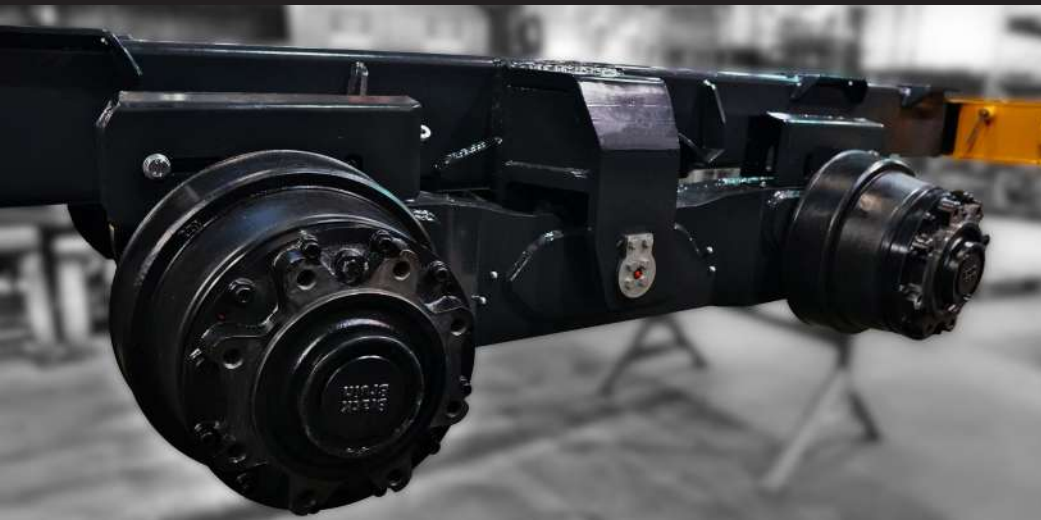

Driving system with Black Bruin motors 2WD / 4WD



The variable displacement system (LS - load sensing) can be optionally equipped with:

* 2 gear hydraulic motors

* motors tractive power adjustment from drive system controller

Black Bruin motors		B240 / 2WD	B240 / 4WD	B250 / 2WD	B250 / 4WD
Torque (gross)	1 m / Nm	12	24	15-27	30-54
Working pressure	bar	250	250	250-280	250-280
Max drive speed with WD	km / h	~3-5	~3-5	~5 (1st gear) ~10 (2nd gear)	~5 (1st gear) ~10 (2nd gear)
Max freewheeling speed	km / h	30	30	30	30

ONIAR



Telescopic tail lights



Foldable tail lights



Hydraulic brakes



Pneumatic brakes



Standing platform for control valve on drawbar with pump connection underneath



Frame extension



Chainsaw holder



Load strap box on support legs



Load strap box on front screen



Fixed parking leg



Height adjustable parking legs





Welded swivel towing eye Ø 50 mm



Bolted fix towing eye Ø 40 mm



Fix towing eye ball coupling Ø 80mm



Bolted fix towing eye Ø 50 mm

The drawbar with fix towing eye + ~250mm

The height of the drawbar hook can be selected based on the height of the tractor hitch

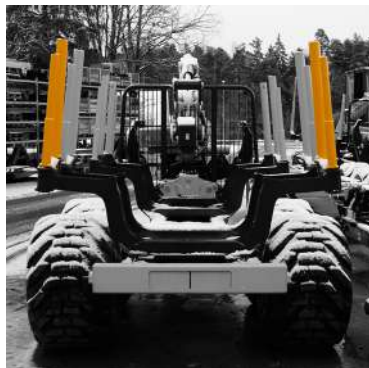

FW TRAILER POLES & EXTENSIONS

ONIA R



Valve block 4/8 XYZ control



**Valve block 4/8 XY control
ON-OFF**



**Valve block full electric
with mini joysticks
FIX / LS**



Parker large joysticks (IP68S)



Mini joysticks with display
Enables operator to adjust and save crane each function setting. Display shows the workload of the crane, which can be used to reduce tractor fuel consumption



Battery operated radio remote control (hall effect joysticks) allows to operate crane either from tractor cabin or next to crane. Remote control is light, compact and available with two speed settings



V support legs



A support legs



Radio controlled winch
operated with crane valve block 9th section



Rotator with hose protection cover



Worklight



Main boom protection cover



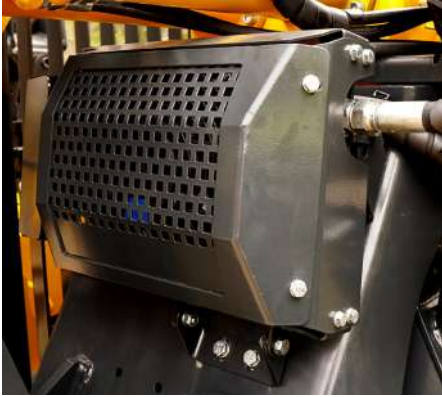

Cooler



Oil tank



Piston pump & multiplier in PTO



Protected piston pump & multiplier on drawbar





Oniar OÜ | Pargi 16 | Märjamaa | Estonia



@OniarOfficial



@Oniarchannel

ONIAR

