



ONIAR



Alates 2022. aasta jaanuarist on kõik Oniari haagised saadaval ELi kogu sõiduki tüübikinnitusega, mis võimaldab Oniari haagiseid registreerida avalikel teedel kasutamiseks. Tüübikinnitust tunnustavad kõik ELi liikmesriigid ja enamik selle naaberriike, kes seda määrust aktsepteerivad.

ELi määrus 167/2013 kehtestab metsa- ja muude põllumajanduslike sõidukite ohutuse ja keskkonnakaitse eeskirjad. Määrusega sätestatakse ühtlustatud tehnilised standardid järeleveetavate sõidukite konstruktsioonile ja üldised nõuded tüübikinnituse omandamiseks.

Suurim lubatud sõidukiirus avalikel teedel on 30 km/h. Tüübikinnituse nõuete täitmiseks peab haagis olema varustatud kas hüdro- või pneumopiduritega ühel- või mõlemal teljel, tagumiste- ja külgmiste tulede ning helkuritega ja kindlat mõõtu ratastega. Ühe- ja kahekontuurse hüdro ning kahekontuurse pneumo pidurisüsteemi valmidusega on Oniari haagised sobilikud enamikule Euroopas müüdavatele traktoritele.

Haagised on jagatud nelja gruppi, mis põhinevad laadimisala ristlõikel ja raamiprofiilil. Tüübikinnitus on saadaval kõigile võimalikele pidurikombinatsioonidele sõltumata kas haagis on varustatud veosüsteemiga või mitte. Haagiste tehnilistest andmetest on võimalik leida iga grupi spetsiifiline täismassi tabel. Nendes on esitatud avalikel teedel lubatud suurim täismass, mis sõltub pidurite arvust, veomootorite asukohast (esi- ja/või tagatelg) ja haagise jaoks ettenähtud rataste suurusel.



Tehniline informatsioon		34
Raamitüüp		Ühe raamipalgiga
Laadimisala ristlõige	m ²	2,1
Raamiprofil	mm	200x200x8
Rummud		80x80 - 6
Rattad		400/60-15,5
Sobivad tõstukid		6800



Grupp 0 täismass	
34	
2 pidurit / 4 pidurit	
10 000 kg / 13 000 kg	

HAAGIS 34 | 400/60-15,5 | Ø 870

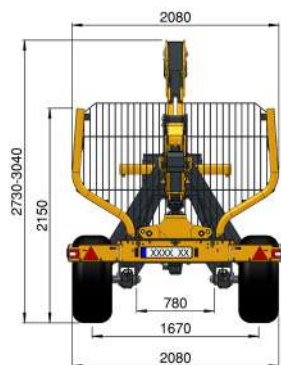
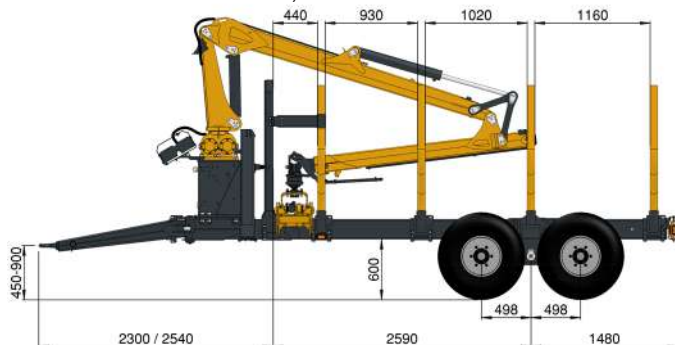

ONIAR

HAAGIS 34 - GRUPP 0



Tehniline informatsioon		134	137	142
Raamitüüp		Kahe raamipalgiga	Kahe raamipalgiga	Kahe raamipalgiga
Laadimisala ristlõige	m ²	2,3	2,3	2,3
Raamiprofiil	mm	2x(200x100x8)	2x(200x100x8)	2x(200x100x8)
Rummud		80x80 - 6	80x80 - 6	90x90 - 8
Rattad		400/60-15,5	500/50-17	550/45-22,5
Sobivad töstukid		6800 / 8000	6800 / 8000 7500	6800 / 8000 7500 / 8750

Grupp 1 täismass		
134	137	142
2 pidurit / 4 pidurit		
10 000 kg / 13 500 kg	10 000 kg / 14 500 kg	12 500 kg / 15 500 kg
2 WD esimesel teljel : 2 pidurit / 4 pidurit		
---- / ----	6600 kg (pneumaatiline) / 9000 kg (pneumaatiline) 8000 kg (hüdrauliline) / 12 000 kg (hüdrauliline)	10 500 kg / 15 500 kg
2 WD tagumisel teljel : 2 pidurit / 4 pidurit		
---- / ----	10 000 kg / 12 000 kg	12 500 kg / 15 500 kg
4 WD : 2 pidurit / 4 pidurit		
---- / ----	6600 kg (pneumaatiline) / 9000 kg (pneumaatiline) 8000 kg (hüdrauliline) / 12 000 kg (hüdrauliline)	10 500 kg / 15 500 kg

Black Bruini mootorid		B240 / 2WD	B240 / 4WD	B250 / 2WD	B250 / 4WD
Pöördemoment (bruto)	1m/Nm	12	24	15-27	30-54
Töösurve	bar	250	250	250-280	250-280
Maksimaalne sõidukiirus veoga	km/h	~ 3-5	~ 3-5	~ 3-5	~ 3-5
Maksimaalne vabaveo kiirus	km/h	30	30	30	30

HAAGIS 134 | 400/60-15,5 | Ø 875

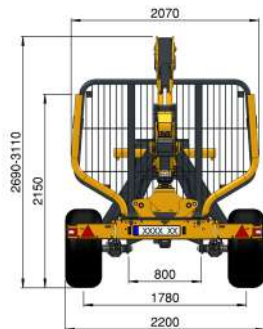
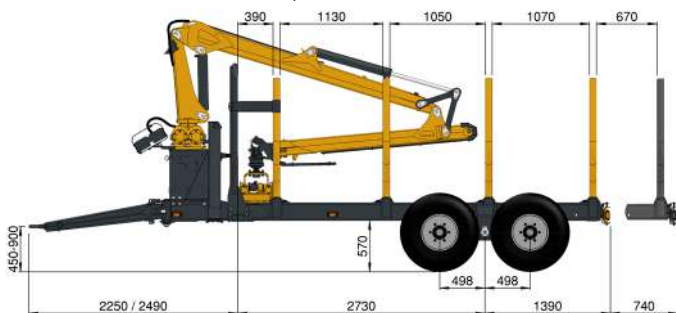

HAAGIS 137 | 500/50-17 | Ø 945

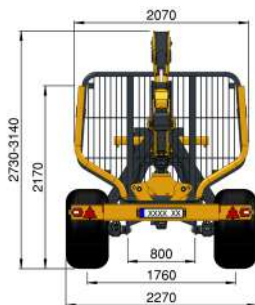
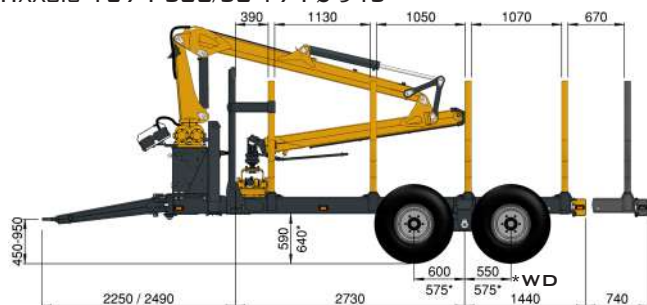

HAAGIS 142 | 550/45-22,5 | Ø 1070

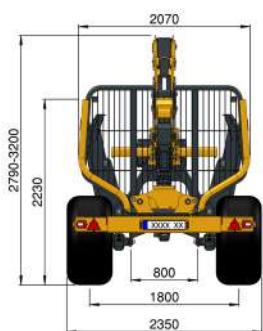
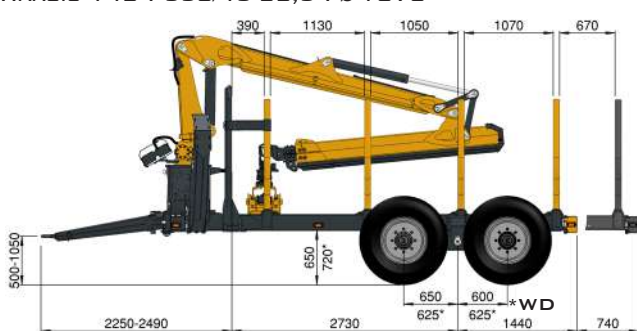

HAAGIS 134 / 137 / 142 TIHEDA POSTIJAOTUSEGA RAAM

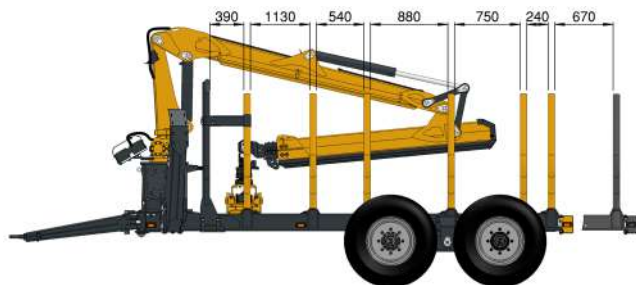

ONIAR

HAAGISED 134 / 137 / 142 - GRUPP 1



Tehniline informatsioon		237	242 / 242 R	246 / 246 R	246 e / 246 Re
Raamitüüp		Kahe raamipalgiga	Kahe raamipalgiga pikendatud (R)	Kahe raamipalgiga pikendatud (R)	Kahe raamipalgiga pikendatud (R)
Laadimisala ristlõige tavapostidega	m ²	2,6	2,6	2,6	2,6
Laadimisala ristlõige võsapostidega	m ²	----	2,4 - 5	2,4 - 5	2,4 - 5
Raamiprofiil	mm	2x(200x120x8)	2x(200x120x8)	2x(200x120x8)	2x(200x120x8)
Rummud	mm	80x80 - 6	90x90 - 8	100x100 - 8	100x100 - 8
Rattad		500/50-17	550/45-22,5	600/50-22,5	710/40-22,5 (e)
Sobivad tõstukid		6800 / 8000 7500	6800 / 8000 7500 / 8750 7400 / 8600	6800 / 8000 7500 / 8750 7400 / 8600	6800 / 8000 7500 / 8750 7400 / 8600

Grupp 2 täismass				
	237	242 / 242 R	246 / 246 R	246 e / 246 Re
2 pidurit / 4 pidurit				
	10 000 kg / 15 000 kg	12 500 kg / 17 000 kg	12 500 kg / 18 000 kg	12 500 kg / 15 000 kg
2 WD esimesel teljel : 2 pidurit / 4 pidurit				
6600 kg (pneuma) / 9000 kg (pneuma) 8000 kg (hüdra) / 12 000 kg (hüdra)		10 500 kg / 16 000 kg	10 500 kg / 17 000 kg	10 500 kg / 15 000 kg
2 WD tagumisel teljel : 2 pidurit / 4 pidurit				
	10 000 kg / 12 000 kg	12 500 kg / 16 000 kg	12 500 kg / 17 000 kg	12 500 kg / 15 000 kg
4 WD : 2 pidurit / 4 pidurit				
	6600 kg (pneuma) / 9000 kg (pneuma) 8000 kg (hüdra) / 12 000 kg (hüdra)	10 500 kg / 16 000 kg	10 500 kg / 17 000 kg	10 500 kg / 15 000 kg

	Black Bruini mootorid		B240 / 2WD	B240 / 4WD	B250 / 2WD	B250 / 4WD
Pöördemoment (bruto)	1m/Nm		12	24	15-27	30-54
Tõõsurve	bar		250	250	250-280	250-280
Maksimaalne sõidukiirus veoga	km/h		~ 3-5	~ 3-5	~ 3-5	~ 3-5
Maksimaalne vabaveo kiirus	km/h		30	30	30	30



HAAGIS 237 | 500/50-17 | Ø 945

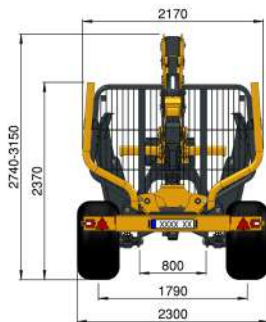
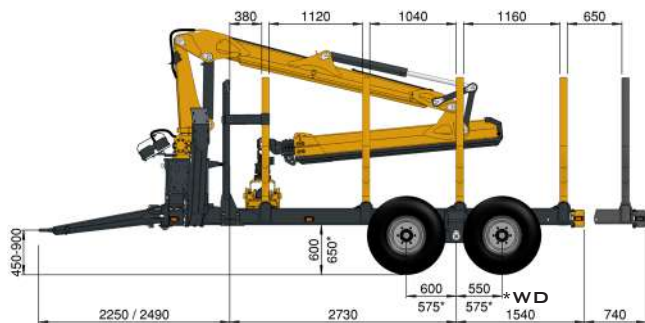

HAAGIS 242 | 550/45-22,5 | Ø 1070

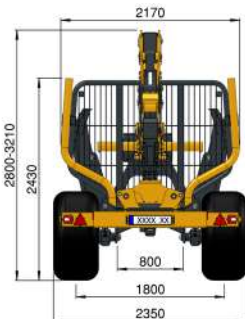
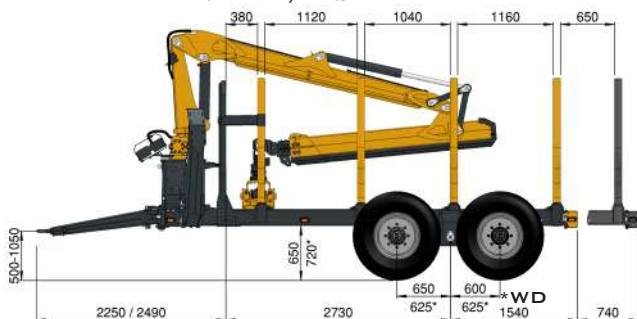

HAAGIS 242R | 550/45-22,5 | Ø 1070

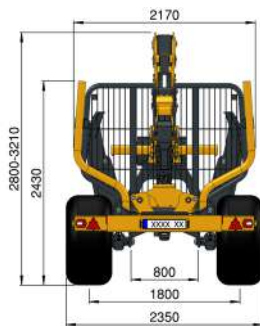
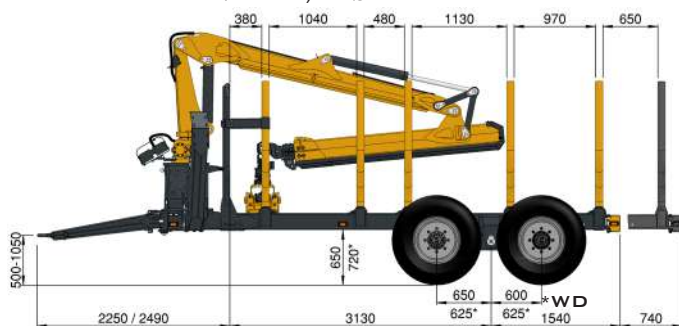

HAAGIS 242R | FW | 550/45-22,5 | Ø 1070

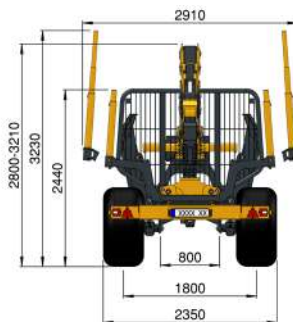
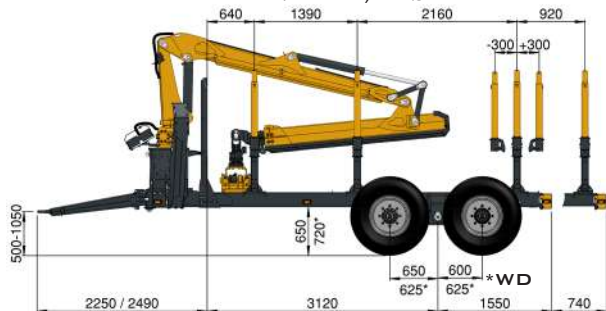

HAAGIS 246 I 600/50-22,5 I Ø 1170

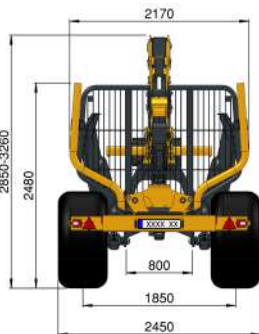
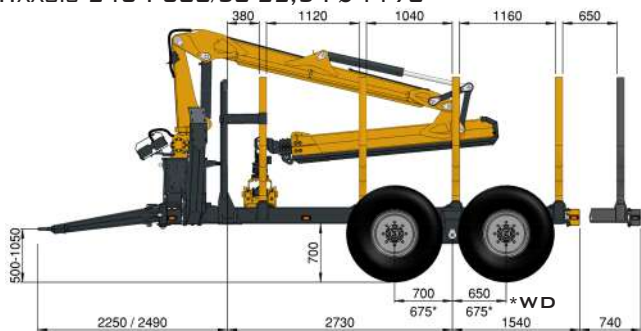

HAAGIS 246R I 600/50-22,5 I Ø 1170

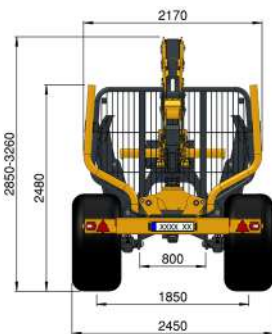
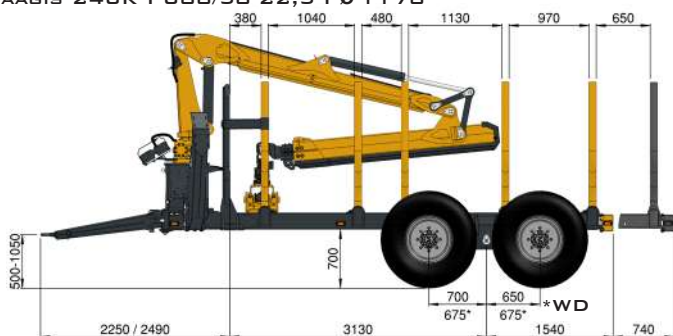

HAAGIS 246R I FW I 600/50-22,5 I Ø 1170

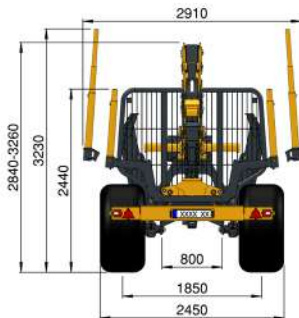
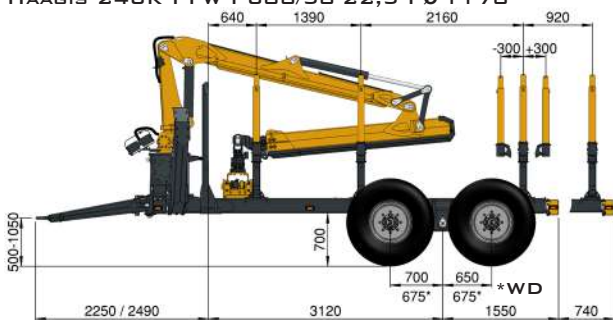

HAAGIS 246E I 710/40-22,5 I Ø 1170

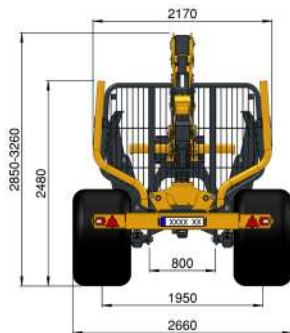
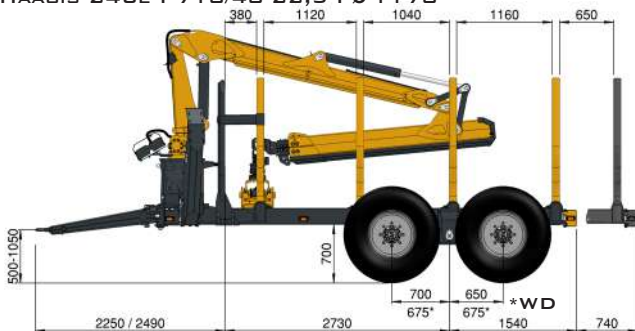

HAAGIS 246RE | 710/40-22,5 | Ø 1170

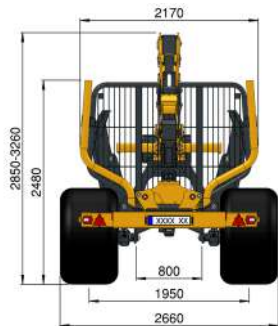
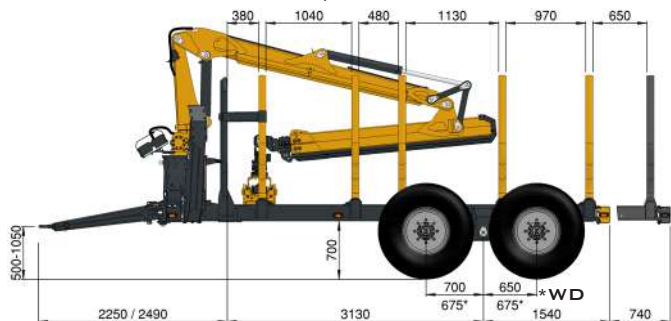

HAAGIS 246RE | FW | 710/40-22,5 | Ø 1170

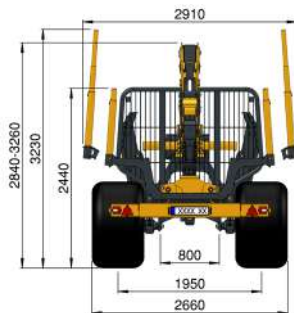
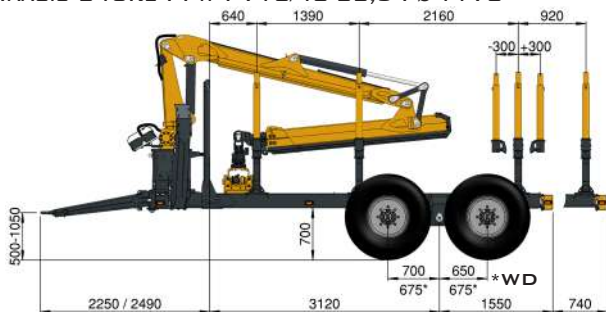

HAAGIS 237 / 242 / 246 TIHEDA POSTIJAOTUSEGA RAAM

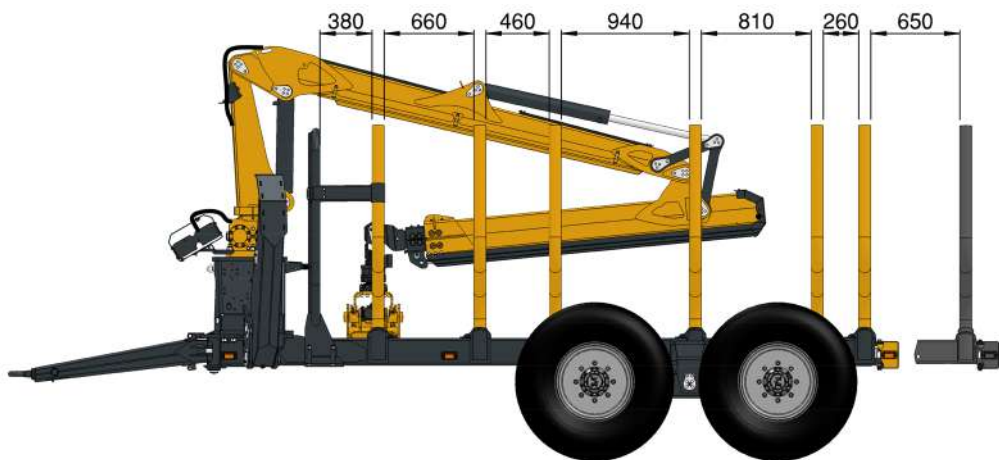



Tehniline informatsioon		342 / 342 R	346 / 346 R	346 e / 346 Re
Raamitüüp		Kahe raamipalgiga pikendatud (R)	Kahe raamipalgiga pikendatud (R)	Kahe raamipalgiga pikendatud (R)
Laadimisala ristlõige tavapostidega	m ²	3	3	3
Laadimisala ristlõige võsapostidega	m ²	2,8 - 5,6	2,8 - 5,6	2,8 - 5,6
Raamiprofiil	mm	2x(250x150x8)	2x(250x150x8)	2x(250x150x8)
Rummud	mm	90x90 - 8	100x100 - 8	100x100 - 8
Rattad		550/45-22,5	600/50-22,5	710/40-22,5 (e)
Sobivad tõstukid		7500 / 8750 7400 / 8600	7500 / 8750 7400 / 8600	7500 / 8750 7400 / 8600

Grupp 3 täismass		
342 / 342 R	346 / 346 R	346 e / 346 Re
2 pidurit / 4 pidurit		
13 000 kg / 19 000 kg	13 000 kg / 20 500 kg	13 000 kg / 16 000 kg
2 WD esimesel teljel : 2 pidurit / 4 pidurit		
11 000 kg / 17 000 kg	11 000 kg / 18 000 kg	11 000 kg / 16 000 kg
2 WD tagumisel teljel : 2 pidurit / 4 pidurit		
13 000 kg / 17 000 kg	13 000 kg / 18 000 kg	13 000 kg / 16 000 kg
4 WD : 2 pidurit / 4 pidurit		
11 000 kg / 17 000 kg	11 000 kg / 18 000 kg	11 000 kg / 16 000 kg

Black Bruini mootorid		B240 / 2WD	B240 / 4WD	B250 / 2WD	B250 / 4WD
Pöördemoment (bruto)	1m/Nm	12	24	15-27	30-54
Tõõsurve	bar	250	250	250-280	250-280
Maksimaalne sõidukiirus veoga	km/h	~ 3-5	~ 3-5	~ 3-5	~ 3-5
Maksimaalne vabaveo kiirus	km/h	30	30	30	30



HAAGIS 342 | 550/45-22,5 | Ø 1070

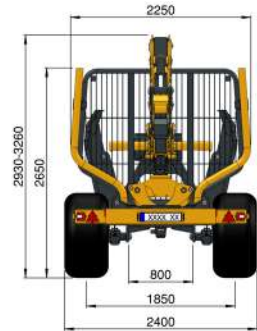
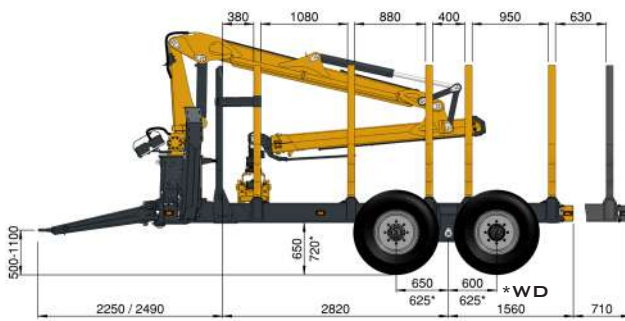

HAAGIS 342R | 550/45-22,5 | Ø 1070

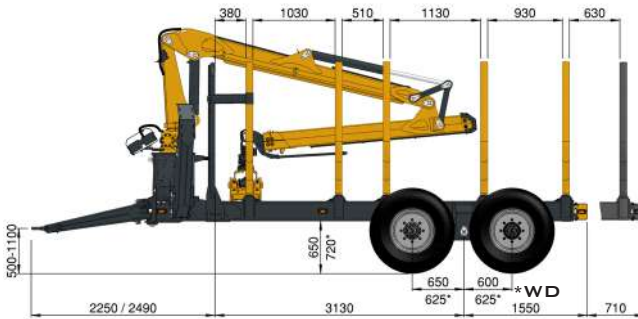

HAAGIS 342 | FW | 550/45-22,5 | Ø 1070

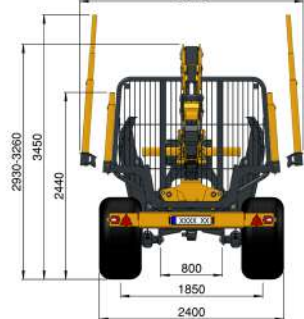
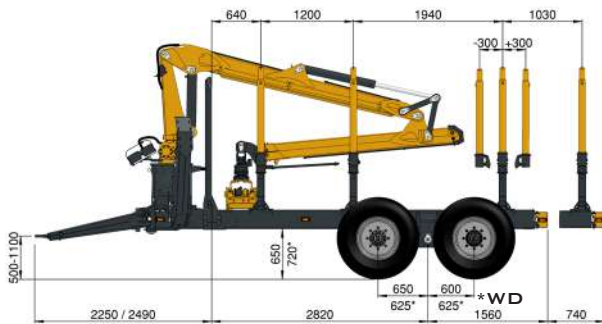

HAAGIS 342R | FW | 550/45-22,5 | Ø 1070

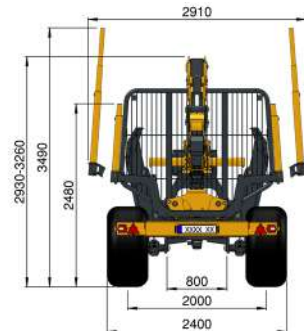
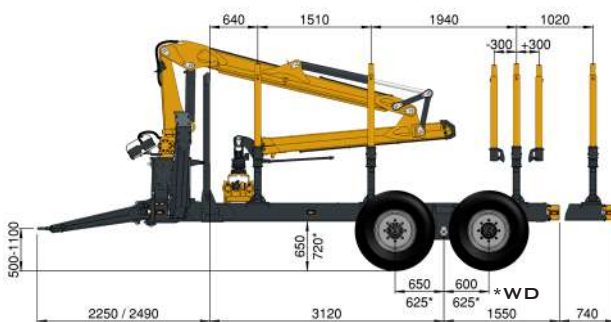

HAAGISED 342 / 346 - GRUPP 3

HAAGIS 346 | 600/50-22,5 | Ø 1170

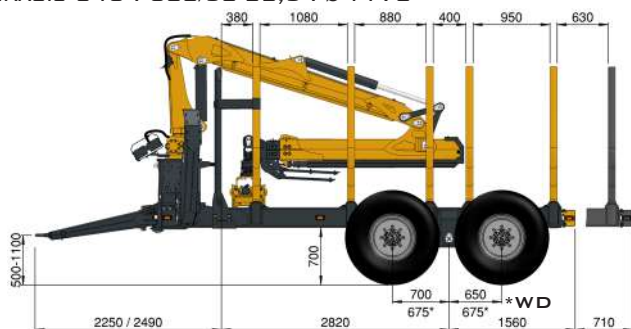

HAAGIS 346R | 600/50-22,5 | Ø 1170

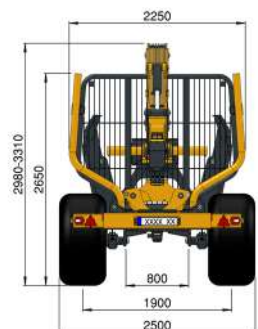
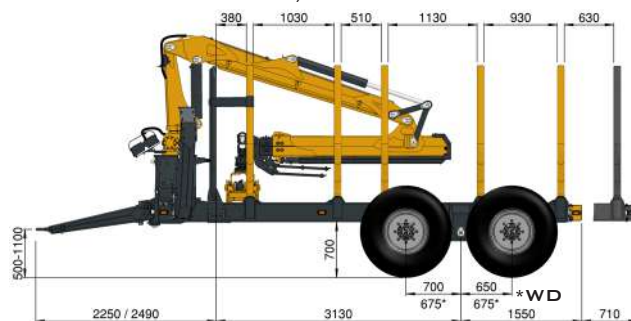

HAAGIS 346E | 710/40-22,5 | Ø 1170

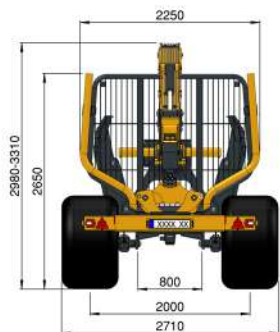
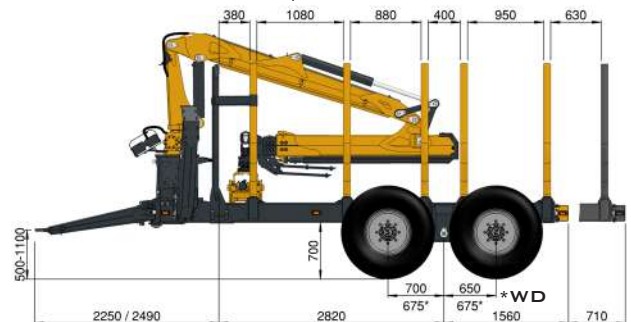

HAAGIS 346RE | 710/40-22,5 | Ø 1170

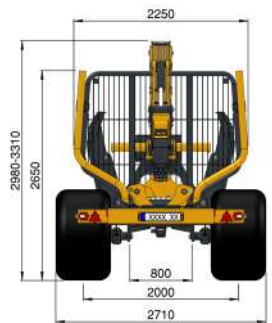
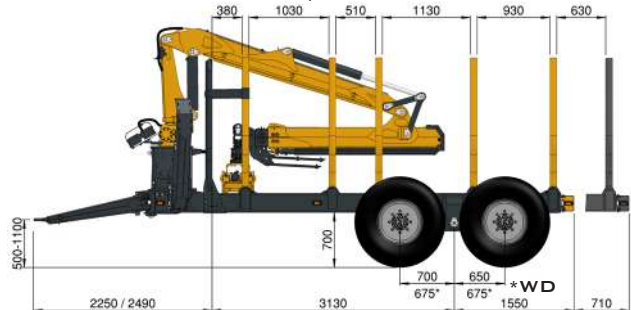

HAAGIS 346 | FW | 600/50-22,5 | Ø 1170

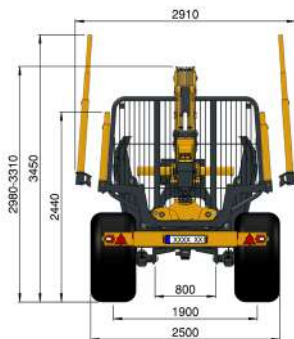
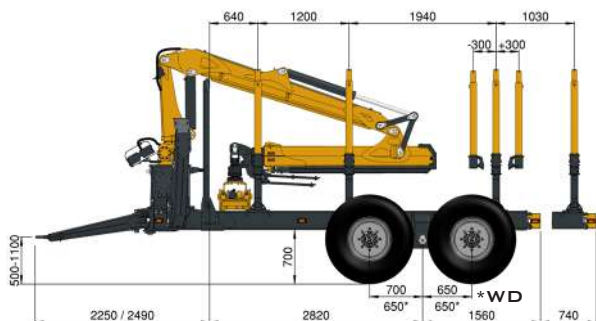

HAAGIS 346R | FW | 600/50-22,5 | Ø 1170

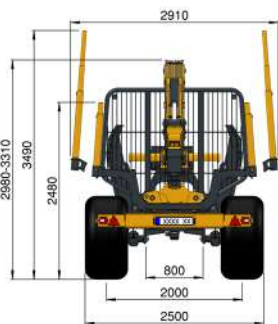
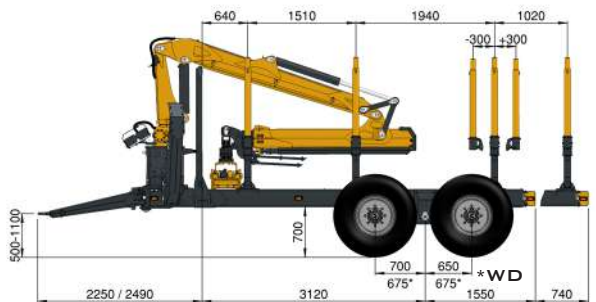

HAAGIS 346E | FW | 710/40-22,5 | Ø 1170

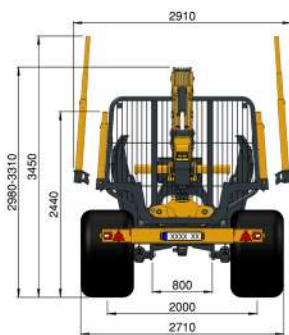
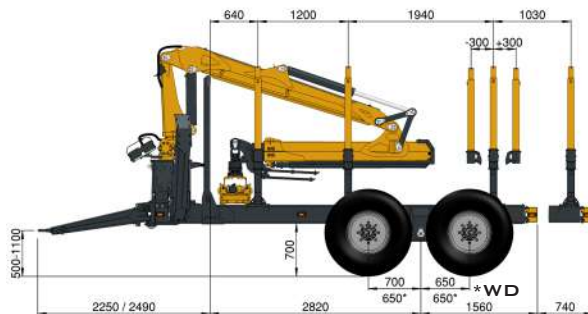

HAAGIS 346RE | FW | 710/40-22,5 | Ø 1170

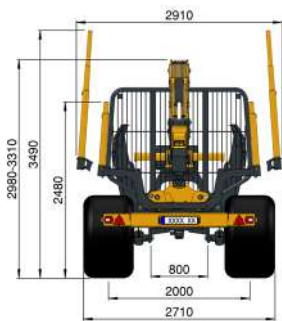
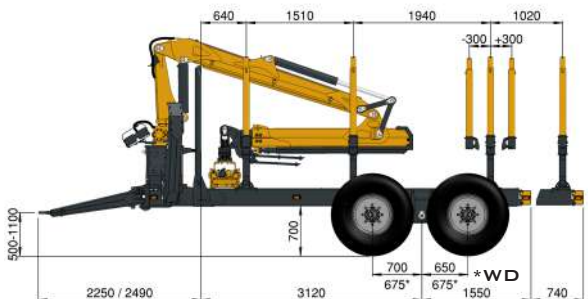

HAAGISED 342 / 346 - GRUPP 3

HAAGIS 342 / 346 TIHEDA POSTIJAOTUSEGA RAAM

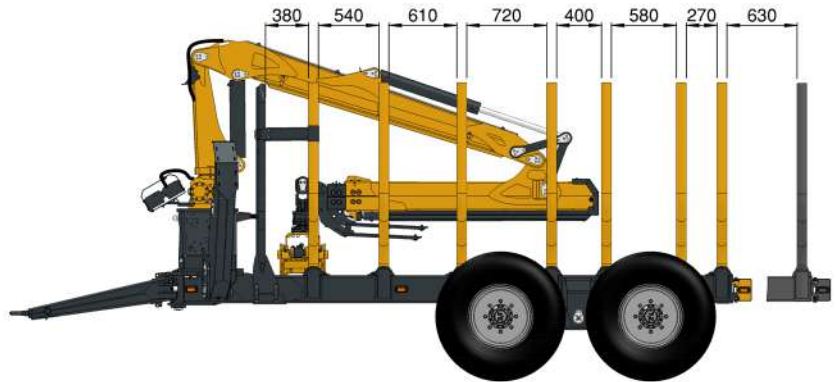

HAAGIS 342R / 346R PIKENDATUD RAAM TIHEDA POSTIJAOTUSEGA

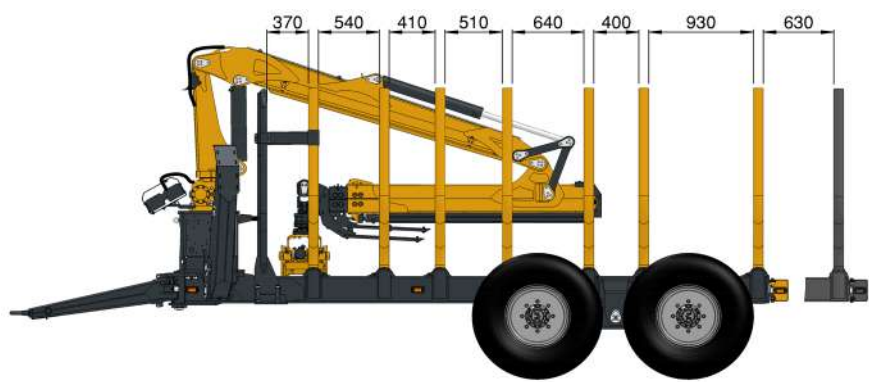



GRUPP 0

2,1 m²

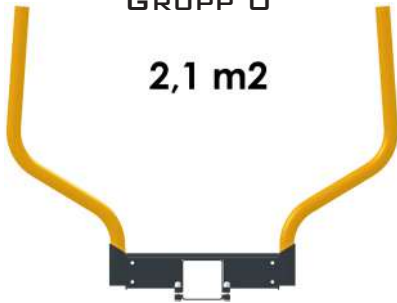

GRUPP 1

2,3 m²



GRUPP 2

2,6 m²



GRUPP 3

3 m²



ONIAR

GRUPP 2 VÕSAPOSTID
KOORMAALA LAIENDUSTETA



2,4 m²

POSTI
PIKENDUSTEGA



3,8 m²

GRUPP 2 VÕSAPOSTID
KOORMAALA LAIENDUSTEGA



2,6 m²

POSTI
PIKENDUSTEGA



4 m²

GRUPP 2 VÕSAPOSTID
KOORMAALA LAIENDUSTEGA
AVATUD ASENDIS



3,2 m²

POSTI
PIKENDUSTEGA



5 m²

ONIAR

KOORMAALA VÕSAPOSTIDE GA - GRUPP 2

**GRUPP 3 VÕSAPOSTID
KOORMAALA LAIENDUSTETA**



2,8 m²

**POSTI
PIKENDUSTEGA**



4,2 m²

**GRUPP 3 VÕSAPOSTID
KOORMAALA LAIENDUSTEGA**



3 m²

**POSTI
PIKENDUSTEGA**



4,4 m²

**GRUPP 3 VÕSAPOSTID
KOORMAALA LAIENDUSTEGA
AVATUD ASENDIS**



3,8 m²

**POSTI
PIKENDUSTEGA**



5,6 m²



TÖSTUKID - 6800 / 8000



ONIAR

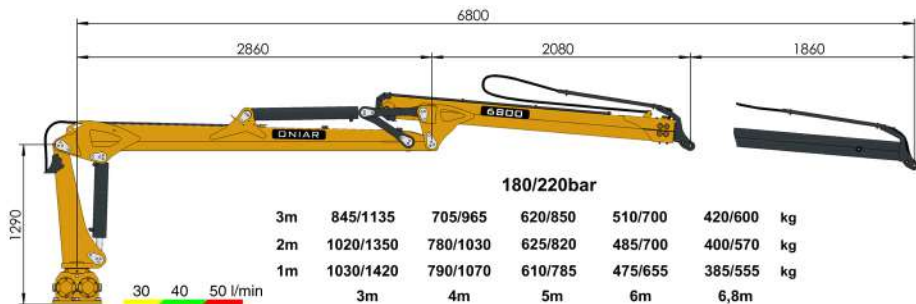

Tehniline informatsioon		6800	8000
Maksimaalne tööulatus	m	6,8	8,0
Töösurve	bar	180 / 220	180 / 220
Tõstemoment (bruto)	kNm	48 / 60	48 / 60
Pöördemoment (bruto)	kNm	15,5 / 19	15,5 / 19
Optimaalne õlivoolu hulk (FIX süsteem)	l/min	30-45	30-45
Roataator	kNm	55	55
Sobivad haagised		34 134 / 137 / 142 237 / 242 / 246	134 / 137 / 142 237 / 242 / 246
Sobivad haaratsid		G18E / G20	G18E / G20

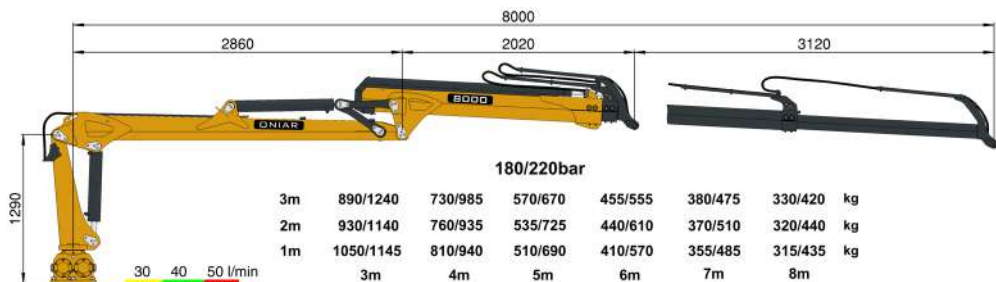

ONIAR

TÕSTUKID - 6800 / 8000

TÕSTUKID - 7500 / 8750 / 8800



ONIAR

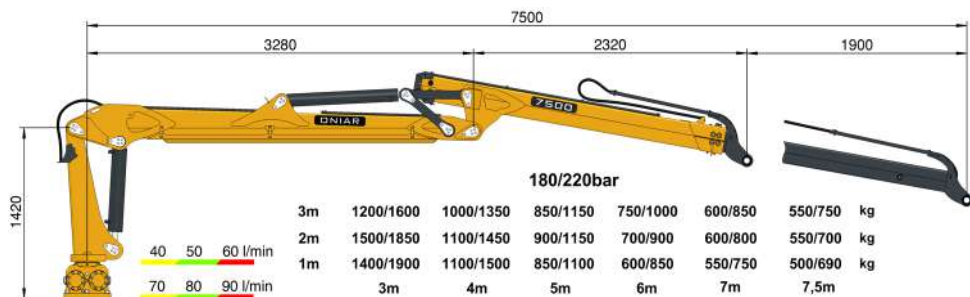

Tehniline informatsioon		7500	8750	8800
Maksimaalne tööulatus	m	7,5	8,75	8,8
Töösurve	bar	180 / 220	180 / 220	180 / 220
Tõstemoment (bruto)	kNm	69 / 85	69 / 85	69 / 85
Pöördemoment (bruto)	kNm	21 / 26	21 / 26	21 / 26
Optimaalne õlivoolu hulk (FIX süsteem)	l/min	45-60	45-60	45-60
Optimaalne õlivoolu hulk (LS süsteem)	l/min	80	80	80
Rotaator	kNm	55	55	55
Sobivad haagised		137 / 142 237 / 242 / 246 342 / 346	142 242 / 246 342 / 346	142 242 / 246 342 / 346
Sobivad haaratsid		G20 / G24 G18E / G22E	G20 / G24 G18E / G22E	G20 / G24 G18E / G22E



TÖSTUKID - 7400 / 8600



ONIAR

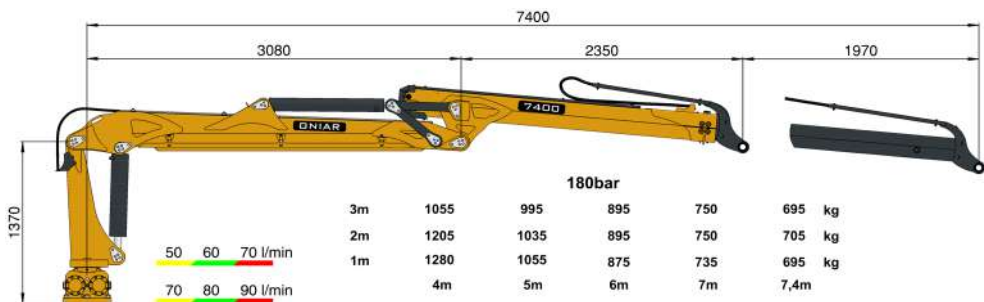

		180bar					
3m	1055	995	895	750	695	kg	
2m	1205	1035	895	750	705	kg	
1m	1280	1055	875	735	695	kg	
	4m	5m	6m	7m	7,4m		

Tehniline informatsioon		7400	8600
Maksimaalne tööulatus	m	7,4	8,6
Töösurve	bar	180	180
Tõstejõud / bruto	kNm	72	72
Pöördemoment / bruto	kNm	21	21
Õlivoolu kogus (FIX süsteem)	l/min	55-65	55-65
Optimaalne õlivoolu hulk (LS süsteem)		80	80
Rotaator	kNm	55	55
Sobivad haagised		242 / 246 342 / 346	242 / 246 342 / 346
Sobivad haaratsid		G24 / G27 / G27H G22E / G25E	G24 / G27 / G27H G22E / G25E



		180bar					
3m	1075	1010	805	710	570	530	kg
2m	1115	1000	850	700	580	530	kg
1m	1190	990	820	685	575	525	kg
	4m	5m	6m	7m	8m	8,6m	

ONIAR

TÖSTUKID - 7400 / 8600

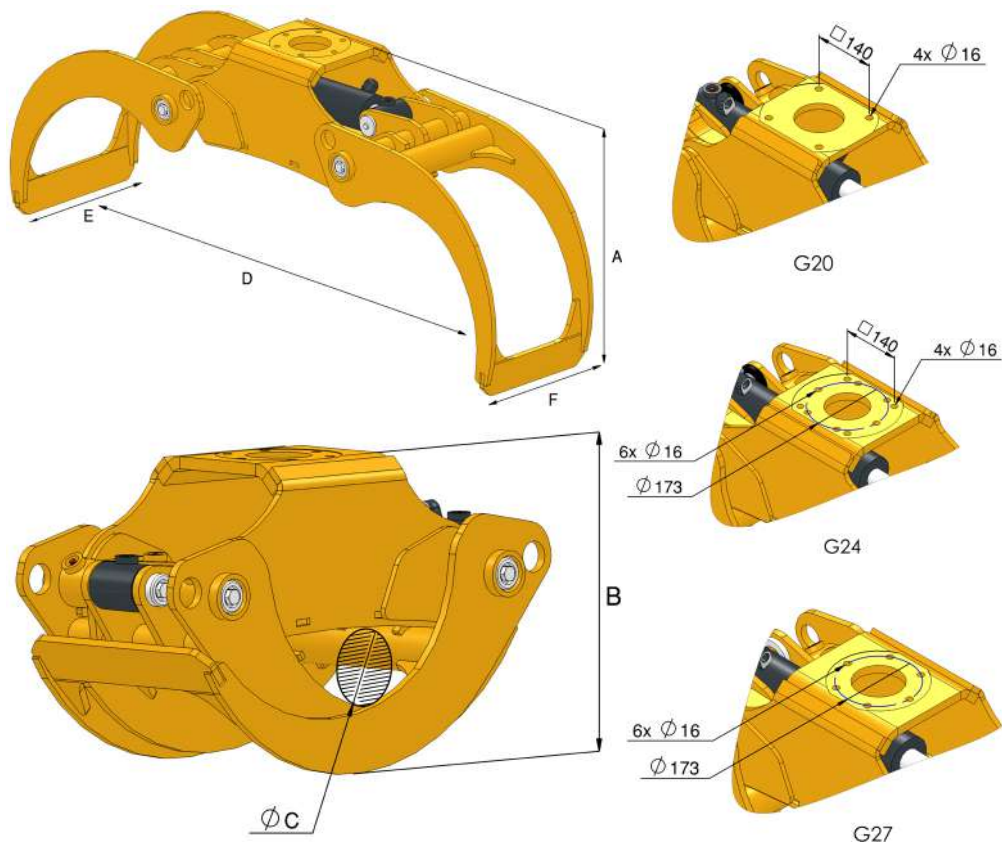

		G20	G24	G27 / G27H
A	mm	620	665	700
B	mm	435	490	505
C	mm	100	115	125
D	mm	1340	1470	1600
E	mm	362	392	412 / 443
F	mm	318	342	362
Kaal	kg	130	180	195 / 215
Pindala	m ²	0,20	0,24	0,27
Töösurve	bar	180-220	180-220	180-220
Haarde kokkusurumis jõud	kN	7,6	11	13,4
Optimaalne õlivooluhulk	l/min	30	40	50

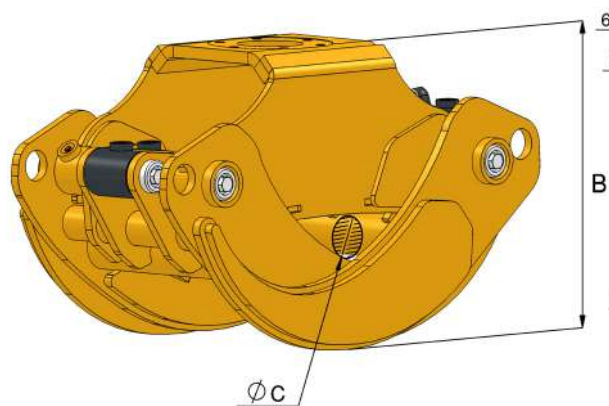
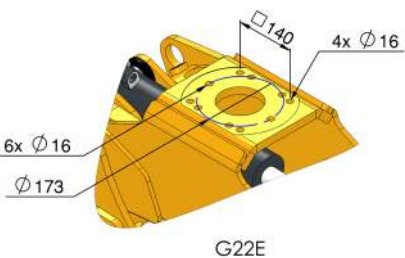
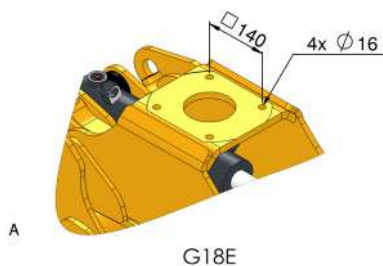
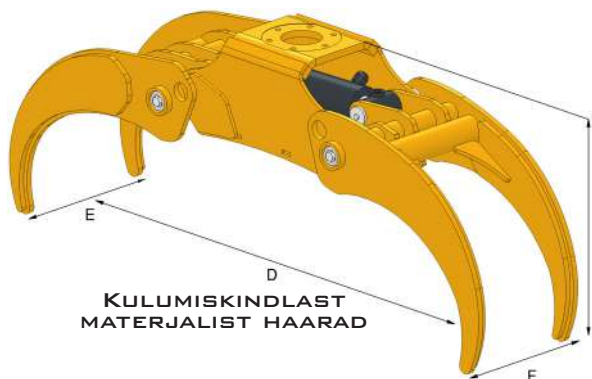

		G18E	G22E	G25E
A	mm	590	685	685
B	mm	435	490	490
C	mm	70	70	70
D	mm	1340	1470	1550
E	mm	390	430	450
F	mm	318	344	364
Kaal	kg	140	215	230
Pindala	m ²	0,18	0,22	0,25
Töösurve	bar	180-220	180-220	180-220
Haarde kokkusurumis jõud	kN	7,6	11	13,4
Optimaalne õlivooluhulk	l/min	30	40	50



Nokian Forest King F2



Põllumajandus rehv



Tugevdatud veljed
ventiili kaitsmega



Metsanduse rehv

	Nokian Forest King F2	Põllumajandus muster (flotation)	Metsanduse muster (traction)	Tugevdatud veljed
400/60-15,5	-	X	-	X
500/50-17	-	X	-	X
550/45-22,5	-	X	X	X
600/50-22,5	X	-	-	X
710/40-22,5	X	-	-	X



Veosüsteem Black Bruin mootoritega 2WD / 4WD



Hüdraulilised pidurid



Pneumaatilised pidurid



Tõstuki juhtimisplatvorm tiisli peal
Pumba ühendus platvormi all



Koormaala pikendus

ONIAR



Teleskoop tagatuled



Kokkuklapitavad tagatuled



Keevis pööratav veosilm Ø 50 mm



Polditav veoepa Ø 80mm



Polditav fikseeritud veosilm Ø 40mm



Polditav fikseeritud veosilm Ø 50mm

Fikseeritud veosilmaga tiisli pikkus + ~250mm

Tiisli kõrgust võimalik valida lähtuvalt traktori konksu kõrgusest

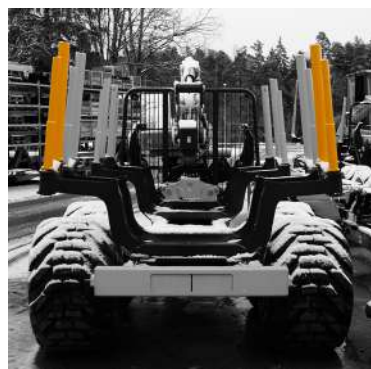

ONIAR



Täismehaaniline jagaja 4/8 XYZ



Mehaaniline jagaja 4/8 XY
ON-OFF



Täiselektriline jagaja mini joystikudega
FIX / LS



Mehaaniline jagaja 4/8 XY
ON-OFF (lisavarustusega)



Parker suured joystikud (IP68S)



Kaugjuhitav pult



V tugijalad



A tugijalad



Rotaatori voolikute kaitse



Töötuli



Peapoomi põhjakaitse

ONIAR

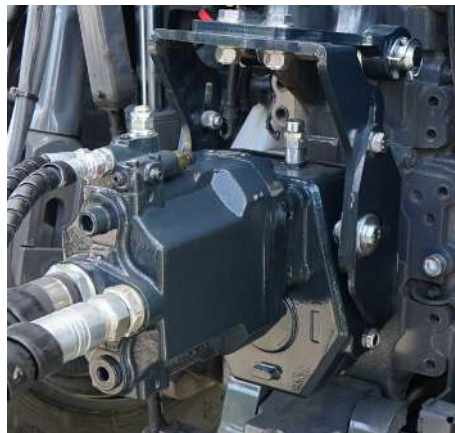

Pump ja reductor PTOs



Pump ja reductor tiislii



Õlipaak



Jahuti



ONIAR



Oniar OÜ | Pargi 16 | Märjamaa | Estonia

Tel: +372 5553 8339 (EST/RUS) / e-post: metsatehnika@oniar.eu

Phone: +372 5556 6171 (ENG) / e-mail: sales@oniar.eu



@OniarOfficial



@Oniarchannel

ONIAR

